

OPERATING AND SERVICE MANUAL

86290A
RF PLUG-IN
2.0 — 18.0 GHz
Includes Options 004 and 005

SERIAL NUMBERS

This manual applies directly to instruments with serial numbers prefixed 1521A.

With changes described in Section VII, this manual also applies to instruments with serial numbers prefixed 1435A and 1450A.

^{INSTRUMENT}
For additional important information about serial numbers see INSTRUMENT COVERED BY MANUAL in Section I.

© Copyright HEWLETT-PACKARD COMPANY 1976
1400 FOUNTAIN GROVE PARKWAY, SANTA ROSA, CA. 95404 U.S.A.

MANUAL PART NO. 86290-90005
Microfiche Part No. 86290-90006
Operating Information Supplement Part No. 86290-90007

Printed: APRIL 1976

CONTENTS

Section	Page	Section
I GENERAL INFORMATION	1-1	3-20. Frequency Reference
1-1. Introduction	1-1	3-22. Phase-Lock Operation
1-6. Specifications	1-1	3-24. X-Y Recorder Operation
1-8. Safety Considerations	1-1	3-29. X-Y Recorder Modification Kit
1-9. General	1-1	3-31. Operator's Maintenance
1-11. Operation	1-1	IV PERFORMANCE TESTS
1-13. Service	1-1	4-1. Introduction
1-18. Instruments Covered by Manual	1-2	4-4. Equipment Required
1-23. Description	1-2	4-6. Test Record
1-28. Option 004	1-3	4-8. Frequency Range and Accuracy Test
1-30. Option 005	1-3	4-9. Frequency Stability Test
1-32. Option 060	1-3	4-10. Power Level and Variation Test
1-34. Accessories Supplied	1-3	4-11. Residual AM Test
1-36. Equipment Required But Not Supplied	1-3	4-12. Spurious Signals Test
1-39. Equipment Available	1-4	4-13. Equivalent Source SWR Test
1-40. Service Accessories	1-4	4-14. External Frequency Modulation Test
1-42. Modification Kits	1-4	4-15. Amplitude Modulation Test
1-44. Reversing Extender Board	1-4	4-16. Frequency Reference Output Test
1-46. RF Section 36-Pin Extender	1-4	V ADJUSTMENTS
1-48. Model 8755A/182C Swept Amplitude Analyzer and Oscilloscope	1-4	5-1. Introduction
1-50. Power Meters and Crystal Detectors	1-4	5-3. Equipment Required
1-52. Model 8410B/8411A Network Analyzer	1-4	5-5. Factory Selected Components
1-54. Recommended Test Equipment	1-4	5-7. Safety Considerations
II INSTALLATION	2-1	5-13. Related Adjustments
2-1. Introduction	2-1	5-15. Abbreviated RF Alignment Procedure
2-3. Initial Inspection	2-1	5-17. Location of Test Points and Adjustments
2-5. Preparation For Use	2-1	5-20. Sweep Control Adjustments
2-6. Power Requirements	2-1	5-21. Stop Sweep Adjustments
2-8. Interconnections	2-1	5-22. YTO Frequency Range Adjustments
2-10. Mating Connectors	2-1	5-23. YTM Slow Speed Tracking Adjustments
2-12. Operating Environment	2-1	5-24. YTM Bias Control and Amplifier Frequency Selective Attenuator (FSA) Adjustments
2-16. Frequency Scale Installation	2-1	5-25. YTM and YTO Delay Compensation Adjustments
2-18. RF Plug-in Installation	2-2	5-26. ALC Adjustments Using 8755A Swept Amplitude Analyzer
2-20. Installation of Options	2-2	5-27. ALC Adjustments (Alternate Procedure)
2-22. Modifications	2-2	5-28. Band Switch Overlap Adjustments
2-25. Storage and Shipment	2-3	5-29. Frequency Reference Calibration Adjustment
2-26. Environment	2-3	5-30. Frequency Modulation Sensitivity Adjustment
2-28. Packaging	2-3	VI REPLACEABLE PARTS
III OPERATION	3-1	6-1. Introduction
3-1. Introduction	3-1	6-3. Abbreviations
3-3. Panel Features	3-1	6-5. Replaceable Parts List
3-5. Operator's Checks	3-1	6-7. Ordering Instructions
3-7. Operating Instructions	3-1	
3-8. Internal Leveling	3-1	
3-10. External Power Meter Leveling	3-1	
3-12. External Crystal Detector Leveling	3-1	
3-14. Internal AM	3-2	
3-16. External AM	3-2	
3-18. External FM	3-2	

MANUAL CHANGES

MANUAL IDENTIFICATION

Model Number: 86290A
Date Printed: April 1976
Part Number: 86290-90005

This supplement contains important information for correcting manual errors and for adapting the manual to instruments containing improvements made after the printing of the manual.

To use this supplement:

Make all ERRATA corrections

Make all appropriate serial number related changes indicated in the tables below.

Serial Prefix or Number	Make Manual Changes	Serial Prefix or Number	Make Manual Changes

► NEW ITEM

► ERRATA

Page 4-32, Paragraph 4-16:

Change step c to read: "c. Adjust CW MARKER pointer to several frequencies across the band while monitoring DVM."

Change step d to read: "d. DVM indication will typically be within 0.050 Vdc of frequency counter indication."

Page 4-37, Paragraph 4-16:

Delete steps c, d, e, and f LOWER LIMIT and UPPER LIMIT. This is a typical characteristic; FREQ REF voltage may be entered at incoming inspection for comparison later.

Page 5-38, Paragraph 5-30:

Change step b to read: "b. Refer to Figure 8-27, NOTE 5 to determine value of A4R46* using FM coil sensitivity noted in step a."

NOTE

Manual change supplements are revised as often as necessary to keep manuals as current and accurate as possible. Hewlett-Packard recommends that you periodically request the latest edition of this supplement. Free copies are available from all HP offices. When requesting copies quote the manual identification information from your supplement, or the model number and print date from the title page of the manual.

3 MAY 1976

Page

Printed in U.S.A.

HEWLETT  PACKARD

CONTENTS (Cont'd)

Page	Section	Page
MANUAL CHANGES		7-1
7-1. Introduction		7-1
7-5. Manual Change Instructions		7-1
7-6. Frequency Selective Attenuator (FSA) Adjustments (CHANGE A)		7-4
7-7. Frequency Modulation Balance Adjustment (CHANGE B)		7-7
7-8. ALC Adjustments Using 8755A Swept Amplitude Analyzer (CHANGE B)		7-8
7-9. ALC Adjustments (CHANGE B)		7-12
7-10. Frequency Modulation Sensitivity Adjustments (CHANGE B)		7-15
 SERVICE		 8-1
8-1. Introduction		8-1
8-2. Assembly Service Sheets		8-1
8-5. Principles of Operation		8-1
8-6. Circuit Description		8-1
8-8. YIG-Tuned Oscillator		8-1
8-16. Troubleshooting		8-2
	8-20. Recommended Test Equipment	8-3
	8-22. Repair	8-3
	8-23. Band Indicator Lamp Replacement	8-3
	8-25. Cleaning Switches	8-3
	8-27. ALC Switch Contact Detail	8-3
	8-29. Unleveled Lamp Removal and Replacement	8-3
	8-31. RF Section Removal and Installation	8-3
	APPENDICES	
	A Option 004 Rear Panel Output	A-1
	A-1. Introduction	A-1
	A-3. Description	A-1
	A-5. Manual Changes to Incorporate Option 004	A-1
	B Option 005 APC-7 RF Output Connector	B-1
	B-1. Introduction	B-1
	B-3. Description	B-1
	B-5. Manual Changes to Incorporate Option 005	B-1

ILLUSTRATIONS

Figure	Page	Figure	Page
1. Model 86290A RF Plug-In with Accessories Supplied	1-0	4-3. Frequency Stability Test Setup	4-8
2. Serial Number Plate	1-2	4-4. 3:1 Load SWR Test Setup	4-10
3. Services Accessories Package, 08620-60124	1-11	4-5. Residual FM Test Setup	4-11
4. Reversing Extender Board, 86290-60033	1-12	4-6. Residual FM Displayed on Spectrum Analyzer	4-12
5. RF Section 36-Pin Extender, 08621-60056	1-12	4-7. Internal Leveling Test Setup	4-14
6. Typical Recorder Plot of Device Under Test and Reference Plots	3-3	4-8. Crystal Detector Leveling Test Setup	4-16
7. Front Panel Controls, Connectors and Indicators	3-4	4-9. Power Meter Leveling Test Setup	4-17
8. Rear Panel Connectors and Switch	3-6	4-10. Residual AM Test Setup	4-19
9. Operator's Checks	3-7	4-11. Spurious Signal Test Setup	4-20
10. Unleveled RF Power Output for Sequential Sweep	3-11	4-12. Equivalent Source Match SWR Test Setup	4-22
11. Leveled RF Power Output for Sequential Sweep	3-11	4-13. Typical Pattern of a Swept SWR Measurement	4-23
12. Unleveled RF Power Output for Single Band	3-11	4-14. Graph for Converting Oscilloscope Trace to Source Match SWR	4-24
13. Leveled RF Power Output for Single Band	3-11	4-15. External Frequency Modulation Test Setup	4-25
14. Oscillations with ALC Loop Gain Too High	3-11	4-16. Spectrum Analyzer Display of Linear Frequency Modulation	4-26
15. External Power Meter Leveling	3-12	4-17. Spectrum Analyzer Display of Non-linear Frequency Modulation	4-26
16. External Crystal Detector Leveling	3-14	4-18. Spectrum Analyzer Display of Second Carrier-null with 900 kHz Modulation Frequency	4-28
17. Switch Positions and Functions for ALC Function Switch AIS1	3-16	4-19. Spectrum Analyzer Display of First Carrier-null with 2.1 MHz Modulation Frequency	4-28
18. Band Indicator Lamp Replacement	3-17	4-20. Amplitude Modulation Test Setup	4-29
19. CW and Manual Sweep Accuracy Test Setup	4-2	4-21. Frequency Reference Output Test Setup	4-31
20. Swept Frequency Endpoint and Marker Accuracy Test Setup	4-5		

ILLUSTRATIONS (Cont'd)

Figure	Page	Figure
5-1. RF Section Labels for YTO and YTM Factory Selected Components and Abbreviated RF Alignment Procedure	5-2	7-9. Upper Power Clamp, Gain Preset, and Power Meter Offset Adjustments Test Setup
5-2. Adjustment Test Setup	5-6	7-10. ALC Adjustments Test Setup
5-3. Stop Sweep Timing Waveform	5-10	7-11. Frequency Modulation Sensitivity Adjustment Test Setup
5-4. YTM Slow Speed Tracking Adjustment Test Setup	5-12	7-12. P/O Figure 8-16. Troubleshooting Block Diagram (2 of 2) (CHANGE A)
5-5. YTM Bias Control and FSA Adjustment Test Setup	5-15	7-13. A10A1 Modulator-Coupler Board, Component Locations (CHANGE A)
5-6. Pin Modulator Driver Voltage With Multiplier Bias Correctly Adjusted.	5-18	7-14. P/O Figure 3-4. Operator's Checks (1 of 4) (CHANGE B)
5-7. Pin Modulator Driver Voltage With FSA Counterclockwise.	5-18	7-15. W1 Flexible Cable Assembly (CHANGE A)
5-8. Pin Modulator Driver Voltage With FSA Correctly Adjusted.	5-18	7-16. RF Section, Major Assembly and Component Locations (CHANGE A)
5-9. Delay Compensation Adjustment Test Setup	5-19	7-17. Location of Test Points (CHANGE B)
5-10. Fast Sweep Compensation Waveform	5-21	7-18. Location of Adjustments (CHANGE B)
5-11. 8755A Calibration Test Setup	5-22	7-19. P/O Figure 3-3. Rear Panel Connectors and Switch (CHANGE B)
5-12. ALC Adjustments Setup Using 8755A Swept Amplitude Analyzer	5-25	7-20. P/O Figure 6-2. Rear Panel Parts Identification (2 of 2) (CHANGE B)
5-13. Detector Compensation Adjustment Waveforms	5-27	7-21. P/O Figure 8-16. Troubleshooting Block Diagram (2 of 2) (CHANGE B)
5-14. GAIN PRESET Adjustment Setup	5-28	7-22. Major Assembly and Component Locations, Top View (CHANGE B)
5-15. Power Meter Leveling Setup	5-29	7-23. A1 ALC Assembly, Component Locations (CHANGE B)
5-16. ALC Adjustments Test Setup.	5-30	7-24. A1 ALC Assembly, Schematic (CHANGE B)
5-17. Detector Compensation Adjustment Test Setup	5-32	7-25. A4 FM Assembly, Component Locations (CHANGE B)
5-18. Band Switch Overlap Adjustment Test Setup	5-34	7-26. A4 FM Assembly, Schematic (CHANGE B)
5-19. Band Switch Overlap Adjustment Waveforms	5-35	7-27. A12A1 YTM Bias Board, Component Locations (CHANGE A)
5-20. Typical Small Overlap Display	5-35	7-28. A12A1 YTM Bias Assembly, Schematic (CHANGE A)
5-21. Typical Large Overlap Display	5-35	8-1. YIG Sphere in Non-Magnetic Field
5-22. 86290A Test Point Locations	5-39	8-2. YIG Sphere in Magnetic Field
5-23. 86290A Adjustment Locations	5-39	8-3. Net Magnetization Vector
5-24. A1 Assembly Adjustment Locations	5-39	8-4. Magnetization Vector With RF Field Applied
5-25. A2 Assembly Adjustment Locations	5-41	8-5. Increase DC Magnetic Field
5-26. A3 Assembly Adjustment Locations	5-41	8-6. Coupling RF and DC Magnetic Fields to YTO YIG
6-1. RF Output Connector J1 Exploded View.	6-19	8-7. Coupling RF and DC Magnetic Fields to YTM YIG Filter
6-2. Rear Panel Parts Identification.	6-20	8-8. ALC Switch S2 Contact Detail.
7-1. FSA Adjustment Test Setup	7-4	8-9. UNLEVELED Lamp Removal and Replacement Procedure.
7-2. Modulator Attenuation Curve with FSA Correctly Adjusted	7-5	8-10. General Information on Schematic Diagrams
7-3. Modulator Attenuation Curve with FSA Counterclockwise	7-6	8-11. Schematic Diagram Notes
7-4. Modulator Attenuation Curve with FSA Incorrectly Adjusted.	7-6	8-12. A1 ALC Assembly, Waveforms.
7-5. Modulator Attenuation Curve with Bias Correctly Adjusted.	7-6	8-13. A2 YTM Driver Assembly, Waveforms.
7-6. Modulator Attenuation Curve with Bias Misadjusted.	7-6	8-14. A3 YTO Driver Assembly, Waveforms.
7-7. Adjustment Test Setup.	7-7	
7-8. Lo Level Clamp/Symmetry and PIN Upper Clamp Adjustments Test Setup.	7-8	

ILLUSTRATIONS (Cont'd)

	Page	Figure	Page
A5 Sweep Control Assembly, Waveforms	8-13	8-35. Front Panel, Component Locations.	8-34
A6 Stop Sweep Assembly, Waveforms	8-13	8-36. A8 Lamp Driver Assembly, Component	
Troubleshooting Block Diagram	8-15	Locations	8-35
Model 86290A Functional Block Diagram	8-19	8-37. A8 Lamp Driver Assembly and Front Panel,	
A1 ALC Assembly, Component Locations	8-21	Schematic	8-35
A1 ALC Assembly, Schematic	8-21	8-38. A9 YTO Component Locations	8-37
A2 YTM Driver Assembly, Component Locations	8-22	8-39. A11 Power Amplifier, Component Locations . .	8-37
A2 YTM Driver Assembly, Test Point and		8-40. A10A1 YTM Bias Control Assembly, Component and	
Adjustment Locations.	8-23	Test Point Locations.	8-37
A2 YTM Driver Assembly, Schematic	8-23	8-41. A10A1 YTM Bias Control Assembly, Schematic	8-37
A3 YTO Driver Assembly, Component Locations	8-24	8-42. A12A1 YTM Heater Control Assembly,	
A3 YTO Driver Assembly, Test Point and Adjustment		Component and Test Point Locations	8-39
Locations	8-25	8-43. A12A1 YTM Heater Control Assembly,	
A3 YTO Driver Assembly, Schematic	8-25	Schematic	8-39
A4 FM Assembly, Component Locations	8-27	8-44. Rear Panel, Component Locations	8-41
A4 FM Assembly, Schematic	8-27	8-45. Rear Panel Wiring Diagram	8-41
A5 Sweep Control Assembly, Component		8-46. W1 Flexible Cable Assembly	8-42
Locations	8-29	8-47. RF Section and Installation Procedure.	8-43
A5 Sweep Control Assembly, Schematic	8-29	8-48. RF Cable Assemblies	8-44
A6 Stop Sweep Assembly, Component		8-49. RF Section, Major Assembly and Component	
Locations	8-31	Locations	8-45
A6 Stop Sweep Assembly, Schematic	8-31	8-50. 86290A Test Point Locations	8-45
A7 Master Board, Component Locations	8-33	8-51. 86290A Adjustment Locations	8-45
A7 Master Board, Interconnect Diagram	8-33	8-52. Major Assembly and Component Locations . . .	8-45

TABLES

	Page	Table	Page
Specifications for 86290A Installed in 8620C	1-5	4-17. High Frequency FM.	4-27
Supplemental Characteristics for 86290A Installed		4-18. Model 86290A Performance Test	
in 8620C	1-7	Record.	4-33
Parts Required for 86290A Options	1-8	5-1. Controls Listed in Adjustment Sequence	5-3
Recommended Test Equipment	1-9	5-2. Factory Selected Components	5-5
Model 86290A Mating Connectors	2-2	5-3. Adjustments By Assemblies.	5-5
Frequency Range Accuracy Specifications	4-1	6-1. Reference Designations and Abbreviations	6-2
CW Mode Accuracy at Low-Frequency Endpoints	4-3	6-2. Replaceable Parts	6-4
CW Mode Accuracy at Mid-Frequencies	4-3	6-3. Code List of Manufacturers	6-18
CW Mode Accuracy at High-Frequency Endpoints	4-4	7-1. Manual Changes By Serial Number	7-1
Manual Sweep Accuracy at Low-Frequency		7-2. A1 Assembly Replaceable Parts (CHANGE B). . .	7-25
Endpoints.	4-4	7-3. A4 FM Assembly Replaceable Parts	
Manual Sweep Accuracy at High-Frequency		(CHANGE B)	7-27
Endpoints.	4-4	7-4. A12A1 YTM Bias Assembly Replaceable Parts	
Swept Frequency Endpoint Accuracy Test.	4-6	(CHANGE A)	7-28
Marker Accuracy Test	4-6	8-1. Service Sheet Cross-Reference	8-5
Frequency Stability Specifications	4-7	8-2. Voltages for A1 ALC Assembly	8-8
Frequency Change with Temperature	4-9	8-3. Voltages for A2 YTM Driver Assembly	8-8
Frequency Change with Power Level.	4-10	8-4. Voltages for A3 YTO Driver Assembly	8-10
Frequency Change with 3:1 Load SWR	4-11	8-5. Voltages for A4 Frequency Modulation	
Residual FM Frequency Deviation	4-12	Assembly	8-10
Power Level and Power Variation Specifications	4-13	8-6. Voltages for A5 Sweep Control Assembly	8-12
Internal Leveling Power Level and Variation.	4-15	8-7. Voltages for A6 Stop Sweep Assembly	8-12
Low Frequency FM	4-27	8-8. Voltages for A8 Lamp Driver Assembly	8-14

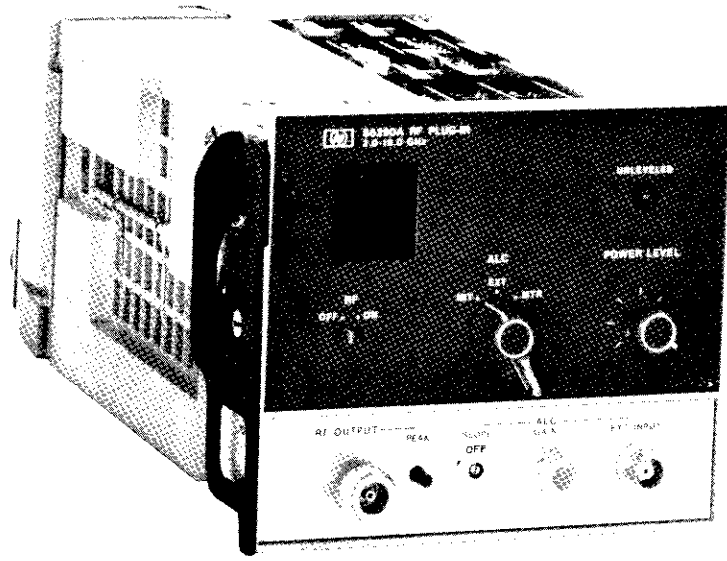

86290A

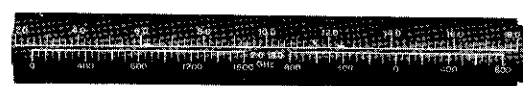
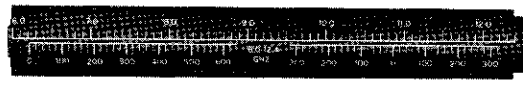
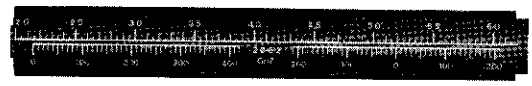

SCALES FOR 8620A and 8620C*



RF TEST CABLE*

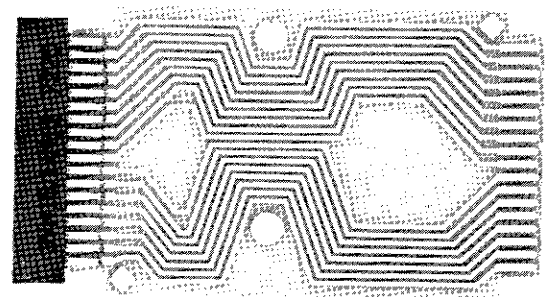

EXTENDER BOARD*

*NOTE: See paragraph 1-28 for part number information

Figure 1-1. Model 86290A RF Plug-In with Accessories Supplied

SECTION I GENERAL INFORMATION

INTRODUCTION

This Operating and Service manual contains information required to install, operate, test, adjust, and service the Hewlett-Packard Model 86290A RF Plug-in. Figure 1-1 shows the instrument and accessories supplied. This section covers instrument identification, description, operation, accessories, specifications, and other basic information.

This manual is divided into eight sections which provide information as follows:

SECTION I, GENERAL INFORMATION, contains the instrument description and specifications as well as the accessory and recommended test equipment list.

SECTION II, INSTALLATION, contains information relative to receiving inspection, preparation for use, mounting, packing, and shipping.

SECTION III, OPERATION, contains operating instructions for the instrument.

SECTION IV, PERFORMANCE TESTS, contains information required to verify that instrument performance is in accordance with published specifications.

SECTION V, ADJUSTMENTS, contains information required to properly adjust and align the instrument after repair.

SECTION VI, REPLACEABLE PARTS, contains information required to order all parts and assemblies.

SECTION VII, MANUAL CHANGES, contains backdating information to make this manual compatible with earlier equipment configurations.

SECTION VIII, SERVICE, contains descriptions of the circuits, schematic diagrams, parts location diagrams, and troubleshooting procedures to aid the user in maintaining the instrument.

1-4. Supplied with this manual is an Operating Information Supplement. The Supplement is a copy of the first three sections of this manual, and should be kept with the instrument for use by the operator. Additional copies of the Operating Information Supplement can be ordered through your nearest Hewlett-Packard office. The part number is listed on the title page.

1-5. Also listed on the title page of this manual is a Microfiche part number. This number can be used to order 4 x 6-inch microfilm transparencies of the manual. Each microfiche contains up to 60 photo-duplicates of the manual pages. The microfiche package also includes the latest Manual Changes supplement as well as all pertinent Service Notes.

1-6. SPECIFICATIONS

1-7. Instrument specifications are listed in Table 1-1. These specifications are the performance standards or limits against which the instrument is tested. Table 1-2 lists supplemental characteristics. Supplemental characteristics are not specifications but are typical characteristics included as additional information for the user.

1-8. SAFETY CONSIDERATIONS

1-9. General

1-10. This is an International Electrotechnical Commission (IEC) Safety Class I instrument. This instrument has been designed and tested according to IEC Publication 348, "Safety Requirements for Electronic Measuring Apparatus," and has been supplied in safe condition.

1-11. Operation

1-12. **BEFORE APPLYING POWER**, refer to **SAFETY CONSIDERATIONS** in Section I of the Operating and Service Manual for the Mainframe.

1-13. Service

1-14. Although the instrument has been designed in accordance with international safety standards, the information, cautions, and warnings in this

manual must be followed to ensure safe operation and to keep the instrument in safe condition. Service and adjustments should be performed only by qualified service personnel.

1-15. Adjustment or repair of the opened instrument with the ac power connected should be avoided as much as possible and, when inevitable, should be performed only by a skilled person who knows the hazard involved.

1-16. Capacitors inside the instrument may still be charged even though the instrument has been disconnected from its source of supply.

1-17. Whenever it is likely that the protection has been impaired, the instrument should be made inoperative and secured against any unintended operation.

WARNING

Any interruption of the protective (grounding) conductor, inside or outside the instrument, or disconnection of the protective earth terminal could make this instrument dangerous. Intentional interruption of the earth ground is prohibited.

Servicing this instrument often requires that you work with the instrument's protective covers removed and with ac power connected. Be very careful; the energy at many points in the instrument may, if contacted, cause personal injury.

CAUTION

BEFORE SWITCHING THIS INSTRUMENT ON, ensure that all devices connected to the instrument are connected to the protective earth ground.

1-18. INSTRUMENTS COVERED BY MANUAL

1-19. Attached to the instrument is a serial number plate (Figure 1-2). The serial number is in two parts. The first four digits and letter are the serial number prefix; the last five digits are the suffix. The prefix is the same for all identical instruments; it changes only when a change is made to the instrument. The suffix, however, is assigned sequentially and is different for each instrument.

1-2

The contents of this manual apply to instruments with the serial number prefix(es) listed under SERIAL NUMBERS on the title page.

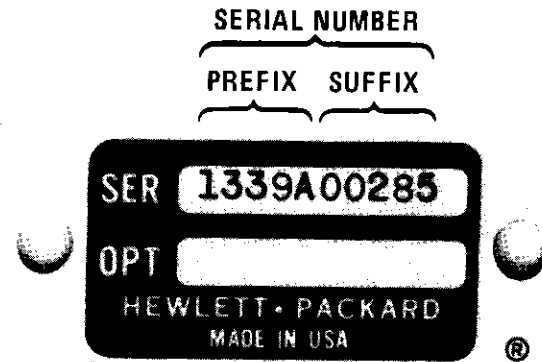

Figure 1-2. Serial Number Plate

1-20. An instrument manufactured after printing of this manual may have a serial number prefix that is not listed on the title page. The unlisted serial number prefix indicates the instrument is different from those described in this manual. The manual for this newer instrument is accompanied by a yellow Manual Changes supplement. This supplement contains "change information" that explains how to adapt the manual to the newer instrument.

1-21. In addition to change information, the supplement may contain information for correcting errors in the manual. To keep this manual as current and accurate as possible, Hewlett-Packard recommends that you periodically request the latest Manual Changes supplement. The supplement for this manual is identified with the manual's print date and part number, both of which appear on the manual's title page. Complimentary copies of the supplement are available from Hewlett-Packard.

1-22. For information concerning a serial number prefix that is not listed on the title page in the Manual Changes supplement, contact your nearest Hewlett-Packard office.

1-23. DESCRIPTION

1-24. The HP Model 86290A is designed as a plug-in for the 8620 Series mainframes. (See paragraph 2-22 for required mainframe modification.) The mainframe and 86290A RF Plug-in make up a solid-state sweep signal source with a frequency range of 2.0 — 18.0 GHz. The frequency

is swept in either one continuous band or in single bands. In single band operation, Band 1 sweeps 2.0 — 6.2 GHz, Band 2 sweeps 6.0 — 12.4 GHz, and Band 3 sweeps 12.0 — 18.0 GHz. When Band 4 is selected on the mainframe, the full frequency range of 2.0 — 18.0 GHz is swept continuously. The fundamental frequency of 2.0 — 3.0 GHz is generated by a YIG Tuned Oscillator (YTO). A YTO test signal (typically -10 dBm) is available at the rear panel AUX OUT connector. A YIG Tuned Multiplier (YTM) provides the frequency range from 6 to 18 GHz.

The RF output of the instrument is controlled by the front panel POWER LEVEL control. Power can be leveled, externally or internally, across the band using a conventional power sampling and feedback technique. The automatic level control (ALC) switch selects the mode of leveling: either internal (INT), external crystal (EXT), or power meter (MTR). A front panel EXT INPUT connector and ALC GAIN control are provided to work with an external leveling loop. When the UNLEVELLED light is on, it indicates that the leveling loop is open over a portion of the swept band. BNC connectors on the rear panel allow for external FM signal inputs, a 1 V/GHz frequency reference voltage output, and a SEQ SYNC timing signal.

7. Options for the Model 86290A RF Plug-in are available to (1) substitute a rear-panel RF OUTPUT connector and also route the EXT INPUT connector to the rear panel. (2) provide a front or rear panel APC-7 RF OUTPUT connector, and (3) modify 8620A mainframes with serial prefixes 1332A and below to have a continuous 2 to 18 GHz sweep mode of operation.

28. Option 004

29. The 86290A Option 004 has the RF OUTPUT and ALC EXT INPUT connectors mounted on the rear panel instead of the front panel. Installation information may be obtained from the nearest Hewlett-Packard Field Service center. Installation of the Option 004 requires the parts listed in Table 1-3. Information for Option 004 is in Appendix A.

30. Option 005

31. The standard 86290A RF Plug-in uses the APC-N RF OUTPUT connector. The 86290A Option 005 provides an APC-7 RF OUTPUT connector. See Table 1-3 for parts required to install

Option 005. Information for Option 005 is in Appendix B.

1-32. Option 060

1-33. The 86290A Option 060 provides a Modification Kit and procedures for modifying 8620A mainframes. The 8620A mainframes, with serial prefix 1332A and below, must be modified to have the complete sequential sweep mode capability. See Table 1-3 for the part number of the modification kit. All information and procedures for Option 060 are provided with the Modification Kit.

1-34. ACCESSORIES SUPPLIED

1-35. Figure 1-1 shows the HP Model 86290A RF Plug-in, the four dial scales to be mounted in the mainframe, the RF Test Cable (HP Part No. 86290-60032) for testing and troubleshooting the RF Section, and an extender board (HP Part No. 86290-60020) to extend printed-circuit boards for troubleshooting. The four scales supplied are as follows: 2.0 — 6.2 GHz, HP Part No. 86290-00014; 6.0 — 12.4 GHz, HP Part No. 86290-00015; 12.0 — 18.0 GHz, HP Part No. 86290-00030; and 2.0 — 18.0 GHz, HP Part No. 86290-00031.

1-36. EQUIPMENT REQUIRED BUT NOT SUPPLIED

1-37. To have a complete operating sweep oscillator unit, the Model 86290A RF Plug-in must be installed in an 8620 Series mainframe; 8620A mainframes with serial prefixes 1332A and below require a modification to operate at fast sweep rates. An 8620A mainframe with serial prefix 1332A and below can be modified with Modification Kit, HP Part Number 8620-60099. (See Table 1-3.)

1-38. The HP Model 8620B mainframe is also compatible with the 86290A RF Plug-in but requires a modification. Order Modification Kit, HP Part Number 8620-60100, from the nearest HP service center. (See Table 1-3 for description and contents of the kit.)

NOTE

All 86290A operation and maintenance procedures in this manual are set up using the HP Model 8620C mainframe. The procedures also apply to the 8620A or 8620B mainframes but the controls are different.

1-39. EQUIPMENT AVAILABLE**1-40. SERVICE ACCESSORIES**

1-41. A Service Accessories package for the 86290A RF Plug-in is available for convenience in aligning and troubleshooting the mainframe and RF Plug-in. The Service Accessories Package as shown in Figure 1-3, contains a plug-in extender cable, extender boards, adjustment tool, and RF service cables. The package may be obtained from Hewlett-Packard by ordering HP Part Number 08620-60124.

1-42. Modification Kits

1-43. Modification kits are available to convert older 8620A mainframes (serial prefixes 1332A and below) and 8620B mainframes to obtain full 86290A capabilities. Refer to Table 1-3 for HP Part numbers and description of the kits.

1-44. Reversing extender Board

1-45. A reversing extender board (Figure 1-4) is available for adjusting and troubleshooting when two circuit boards are extended at the same time. The reversing extender board is especially convenient when two adjacent boards are extended. This allows simultaneous access to the components of both boards. One board is extended on the reversing extender board with a second board on the standard extender board (Figure 1-1). The board may be obtained from Hewlett-Packard by ordering Part No. 86290-60033.

1-46. RF Section 36-Pin Extender

1-47. A 36-pin extender is available for extending the RF Section approximately 1 inch. This

allows easy access to components located near the front of the instrument. This extender, shown in Figure 1-5, may be obtained from Hewlett-Packard by ordering Part No. 08621-60056.

1-48. Model 8755A/182C Swept Amplitude Analyzer and Oscilloscope

1-49. The Model 8620C/86290A Sweeper is compatible with the Hewlett-Packard Model 8755A Swept Amplitude Analyzer. For all swept amplitude measurements, the 27.8 kHz square wave modulation is applied directly to the 8620C rear-panel EXT AM connector. This eliminates the need for an external modulator, thus providing maximum available power to a test setup.

1-50. Power Meters and Crystal Detectors

1-51. The Hewlett-Packard Model 432A Power Meter may be used for external leveling of the Model 86290A Plug-in. External leveled power is also available using an HP 8470A Crystal Detector. Section III contains detailed instructions for using the external power leveling systems.

1-52. Model 8410B/8411A Network Analyzer

1-53. The Model 8620C/86290A Sweeper provides multi-octave phase/gain measurement capability with the Hewlett-Packard Model 8410B Network Analyzer System. The combination of the Model 8410B Network Analyzer, the Model 8411A Frequency converter, and an appropriate display plug-in forms a phase meter and a ratio meter for direct phase and amplitude ratio measurement on RF voltages. These measurements can be made on single frequencies and on swept frequencies from 2.0 to 18.0 GHz. The interface between the 8410B and 8620C/86290A sweeper permits the 8410B to phase lock over the 2.0 to 18.0 GHz range. Sweep timing pulses for the 8410B Network Analyzer are available at the rear-panel SEQ SYNC connector.

1-54. RECOMMENDED TEST EQUIPMENT

1-55. Equipment required to maintain the Model 86290A is listed in Table 1-4. Other equipment may be substituted if it meets or exceeds the critical specification listed in the table

Table 1-1. Specifications for 86290A Installed in 8620C (1 of 2)

SPECIFICATIONS ¹				
	Band 1	Band 2	Band 3	Band 4
FREQUENCY				
Range:	2.0 – 6.2 GHz	6.0 – 12.4 GHz	12.0–18.0 GHz	2.0–18.0 GHz
Accuracy (at 25° C):² CW Mode ³ (or Sweep Time > 0.1 sec with FM switch in PL or FM):	±20 MHz	±20 MHz	±20 MHz	±80 MHz
All Sweep Modes:	±30 MHz	±30 MHz	±30 MHz	±80 MHz
Marker:	±30 MHz	±30 MHz	±30 MHz	±80 MHz
Stability:				
Temperature Change:	±0.5 MHz/°C	±1.0 MHz/°C	±1.5 MHz/°C	±2.0 MHz/°C
10% Line Voltage Change:	±100 kHz	±100 kHz	±100 kHz	±100 kHz
10 dB Power Change from Specified Maximum Power	±200 kHz	±400 kHz	±600 kHz	±600 kHz
3:1 Load SWR, all phases:	±100 kHz	±200 kHz	±300 kHz	±300 kHz
Residual FM (in 10 kHz bandwidth; FM-NORM-PL switch in NORM position): CW Mode:	<10 kHz peak	<20 kHz peak	<30 kHz peak	<30 kHz peak
POWER OUTPUT				
Maximum Levelled Power (25° C):⁸	> +5.0 dBm (3.1 mW)	> +5.0 dBm (3.1 mW)	> +5.0 dBm (3.1 mW)	> +5.0 dBm (3.1 mW)
Power Variations (at maximum levelled power):				
Internally Levelled:	<± 0.7 dB	<± 0.7 dB	<± 0.8 dB	<± 0.9 dB
Externally Levelled ⁴ Crystal Detector:	<±0.15 dB	<±0.15 dB	<±0.15 dB	<±0.15 dB
Power Meter: ⁵	<±0.15 dB	<±0.15 dB	<±0.15 dB	<±0.15 dB
Spurious Signals (below fundamental at specified maximum power, 2–18 GHz):				
Harmonically Related Signals:	> 25 dB	> 25 dB	> 25 dB	> 25 dB
Nonharmonics:	> 50 dB	> 50 dB	> 50 dB	> 50 dB
Residual AM: AM noise in 100 kHz band- width (below fundamental at specified maximum power):				
	> 55 dB	> 55 dB	> 55 dB	> 55 dB
Source SWR, 50Ω Nominal Impedance:				
Internally Levelled:	< 1.9:1	< 1.9:1	< 1.9:1	< 1.9:1
MODULATION				
External FM				
Maximum Deviations for Modulation Frequencies:				
DC to 100 Hz:	±75 MHz	±75 MHz	±75 MHz	±75 MHz
100 Hz to 2 MHz:	± 5 MHz	± 5 MHz	± 5 MHz	± 5 MHz

Table 1-1. Specifications for 86290A Installed in 8620C (2 of 2)

SPECIFICATIONS ¹				
MODULATION (Cont'd)	Band 1	Band 2	Band 3	Band 4
Sensitivity (nominal):⁶ FM Mode (FM-NORM-PL switch in FM position):	-20 MHz/V	-20 MHz/V	-20 MHz/V	-20 MHz/V
Phase-Lock Mode (FM-NORM-PL switch in PL position):	-6 MHz/V	-6 MHz/V	-6 MHz/V	-6 MHz/V
External AM (at specified maximum power):⁷ ON/OFF Ratio:	>30 dB	>30 dB	>30 dB	>30 dB
Symmetry:	45/55	45/55	45/55	45/55
Attenuation for +5 volt Input:	30 dB	30 dB	30 dB	30 dB
Internal AM (below maximum leveled power): 1 kHz squarewave ON/OFF Ratio:	> 25 dB	>25 dB	> 25 dB	> 25 dB
RF Blanking ON/OFF Ratio:	> 30 dB	>30 dB	> 30 dB	> 30 dB
<p>¹ All specifications are at 25 degrees C. Allow 30 minutes warmup time.</p> <p>² See also the Supplemental Characteristics, Table 1-2.</p> <p>³ Approach desired frequency from low-frequency end of band.</p> <p>⁴ Excluding coupler and detector variation.</p> <p>⁵ Use HP Model 432A power meter. Sweep duration > 10 seconds.</p> <p>⁶ A positive input voltage decreases frequency.</p> <p>⁷ Specific requirements for compatibility with HP 8755A, $\pm 6V$, 27.8 kHz square wave MODULATOR DRIVE output connected to external AM input.</p> <p>⁸ Subtract 0.5 dB for Option 004.</p>				

Table 1-2. Supplemental Characteristics for 86290A Installed in 8620C (1 of 2)

SUPPLEMENTAL CHARACTERISTICS				
NOTE: Values in this table are not specifications but are typical characteristics included for user information.				
FREQUENCY	Band 1	Band 2	Band 3	Band 4
Linearity: (Correlation between frequency and SWEEP OUT voltage in MANUAL mode): Sweep Time >0.1 sec:	±8 MHz	±8 MHz	±8 MHz	±30 MHz
Drift: (10 minute period after 30 minute warmup):	± 300 kHz	± 600 kHz	±900 kHz	± 900 kHz
POWER OUTPUT				
Power Level: Stability with temperature change:	±0.1 dB/°C	±0.1 dB/°C	±0.1 dB/°C	±0.1 dB/°C
Power Level control range while maintaining 60-40 symmetry of internal 1 kHz square wave):	>10 dB	>10 dB	>10 dB	>10 dB
MODULATION				
External AM (at specified maximum power): Rise Time:	<1.5 μsec	<1.5 μsec	<1.5 μsec	<1.5 μsec
Internal AM: Sweep Time (at maximum sweep speed):	10 msec	10 msec	10 msec	10 msec
CW Remote Programming Settling Time: (FM switch in PL or FM):	5 msec	5 msec	5 msec	10 msec
GENERAL				
<p>Crystal Input: Approximately 25 to 350 mV for specified leveling at rated output; for use with negative polarity detectors such as HP Model 780 series Directional Detectors, and HP Models 8470A and 8472A series Crystal Detectors.</p>				
<p>Switch Points (Band 4 selected): Broadband switch points are at 6.2 and 12.4 GHz. Frequency overlap is nominally 0 to 20 MHz at switch points.</p>				

Table 1-2. Supplemental Characteristics for 86290A Installed in 8620C (2 of 2)

GENERAL (Cont'd)	
Fundamental Oscillator: YIG Tuned 2.0 to 6.2 GHz Oscillator. Oscillator signal available at rear panel AUX OUT connector, typically -10 dBm.	
Net Weight: 9.6 pounds (4,4 kg).	
Shipping Weight: 13 pounds (5,9 kg).	
Dimensions: Height: 5 inches (12,7 cm); Width: 5-13/16 inches (14,7 cm); Depth: 12 inches (30,5 cm).	
Options:	
Option 004: Rear Panel RF Output.	
Option 005: APC-7 RF Output Connector.	
Option 060: Modification Kit to modify 8620A mainframes (see paragraph 1-32).	

Table 1-3. Parts Required for 86290A Options

Option	Reference Designator	HP Part No.	Description
004	W11 J9 J10	86290-00004 86290-00023 86290-20031 86290-60005 1250-0118	Panel: Front Lower Cover: Rear Panel RF Cable: RF Coupler to Output Connector: Rear RF Output Connector: Rear EXT ALC INPUT
005 004/005	J1 J6	86290-60007 86290-60007	Connector: APC-7 Connector: Rear, APC-7
060		08620-60099	8620A Mainframe Modification Kit. The kit includes an A1 Sweep Generator Board, HP Part No. 08620-60095, and installation procedures.
		08620-60100	8620B Mainframe Modification Kit. The kit includes an A1 Sweep Generator Board, HP Part No. 08620-60095; four scales: 2.0-6.2 GHz, HP Part No. 86290-00018, 6.0-12.4 GHz, HP Part No. 86290-00019; 12.0-18.0 GHz, HP Part No. 86290-00032; and 2.0-18.0 GHz, HP Part No. 86290-00033; and installation procedures.

Table 1-4. Recommended Test Equipment (1 of 2)

Instrument	Critical Specifications	Recommended Model	Use
Sweep Oscillator	No substitute mainframe	HP 8620A, 8620B, or 8620C	P,A,T
Spectrum Analyzer (with external mixer)	Frequency Range: 2.0 GHz to 40 GHz	HP 8555A/8552B/141T HP 11517A	P
Oscilloscope with Dual-Trace Vertical Amplifier and 10:1 probes	Vertical Amplifier: Dual trace with 10:1 probes Bandwidth: 20 MHz minimum Vertical Sensitivity: 5 mV/Div Horizontal Sweep Rate: 1 μ s/Div minimum	HP 182C/1801A/1820C	P,A,T
DC Digital Voltmeter	Range: -50V to +50V Accuracy: \pm 0.004% Input Impedance: 10 megohms minimum	HP 3460B	A,T
Swept Amplitude Analyzer and Oscilloscope Mainframe	Frequency Range: 100 MHz to 18 GHz	HP 8755A/182C with Option 807	A
Detectors (2 required)	Frequency Response: 0.1 - 18 GHz, Error < 1.3 dB Impedance: 50 ohms	HP 11664A	A
Frequency Counter	Range: 2.0 to 18.0 GHz	HP 5340A	P,A,T
Function Generator	Frequency: 10 Hz to 2 MHz Output: 6V p-p into 50 ohms	HP 3310A	P
RMS Voltmeter	Scale: RMS volts Range: 0 to -70 dB Accuracy: \pm 5% Frequency Range: 10 Hz to 100 kHz	HP 3400A	P
Power Meter and Thermistor Mount	Frequency: 100 MHz to 18 GHz Range: +10 dBm to -20 dBm	HP 432A/8478B	P
DC Power Supply	Range: 0 to 10 Vdc Current: 0.1 Amp	HP 721A	P
Adjustable AC Line Transformer	Output: 100 to 150 Vac Power: 150 watts	General Radio MT3A	P
Frequency Meter	Range: 2.0 to 4.2 GHz	HP 536A	P
Frequency Meter	Range: 3.7 to 12.4 GHz	HP 537A	P
Frequency Meter	Range: 12.4 to 18.0 GHz	HP P532A	P
Adapter	Coaxial to waveguide	HP P281B	P
Power Splitter	Frequency: 2 - 18 GHz Attenuation in each arm: 6 dB	HP 11667A	P
Directional Coupler	Freq: 2.0 - 18.0 GHz Coupling: 20 dB Directivity: >25 dB SWR all ports: < 1.3 Type-N Male Connector at Input port	HP 11691D, Option CO-1	P

Table 1-4. Recommended Test Equipment (2 of 2)

Instrument	Critical Specifications	Recommended Model	Use*
Air Line (2 required)	20-cm long, APC-7 connectors	HP 11567A	P
Crystal Detector (2 required)	Frequency: 0.01 to 18 GHz SWR: <1.5 to 12.4 GHz <1.7 to 18 GHz	HP 8470A	P
3 dB Attenuator	Attenuation: 3 dB \pm 0.3 dB Frequency: DC to 18 GHz	HP 8491B Option 003	P,A,T
10-dB Attenuator	Attenuation: 10 dB \pm 0.5 dB Frequency: DC to 18 GHz	HP 8491B, Option 020	P,A,T
20-dB Attenuator	Attenuation: 20 dB \pm 0.5 dB Frequency: DC to 18 GHz	HP 8491B,	T
Adapter (2 required)	Type-N male to APC-7	HP 11525A	P
Adjustable Short	Frequency Range: 2.0 to 18.0 GHz	Microlab/FXR SO-6MN	P
Service Board**	(See Figure 1-3)	HP 08620-60037	P,A,T
18-Pin Extender Board**	(See Figure 1-3)	HP 5060-2041	T
RF Service Cable**	Impedance: 50 ohms Connectors: SMA to SMA (Figure 1-3)	HP 8120-1578	T
Cable	2-ft. long, BNC connectors	HP 11086A	P
Extender Cable**	(See Figure 1-3)	HP 08620-60032	T
BNC Tee (2 required)	Connectors: BNC jack and plug	HP 1250-0781	P,A
Adjustment Tool**	(See Figure 1-3)	HP 8830-0024	A
RF Connector Adapter**	SMA jack to SMA jack (Figure 1-3)	HP 1250-1158	T
<p>* P = Performance Test; A = Adjustments; T = Troubleshooting</p> <p>** These parts are included in Service Accessories Package 08620-60124.</p>			

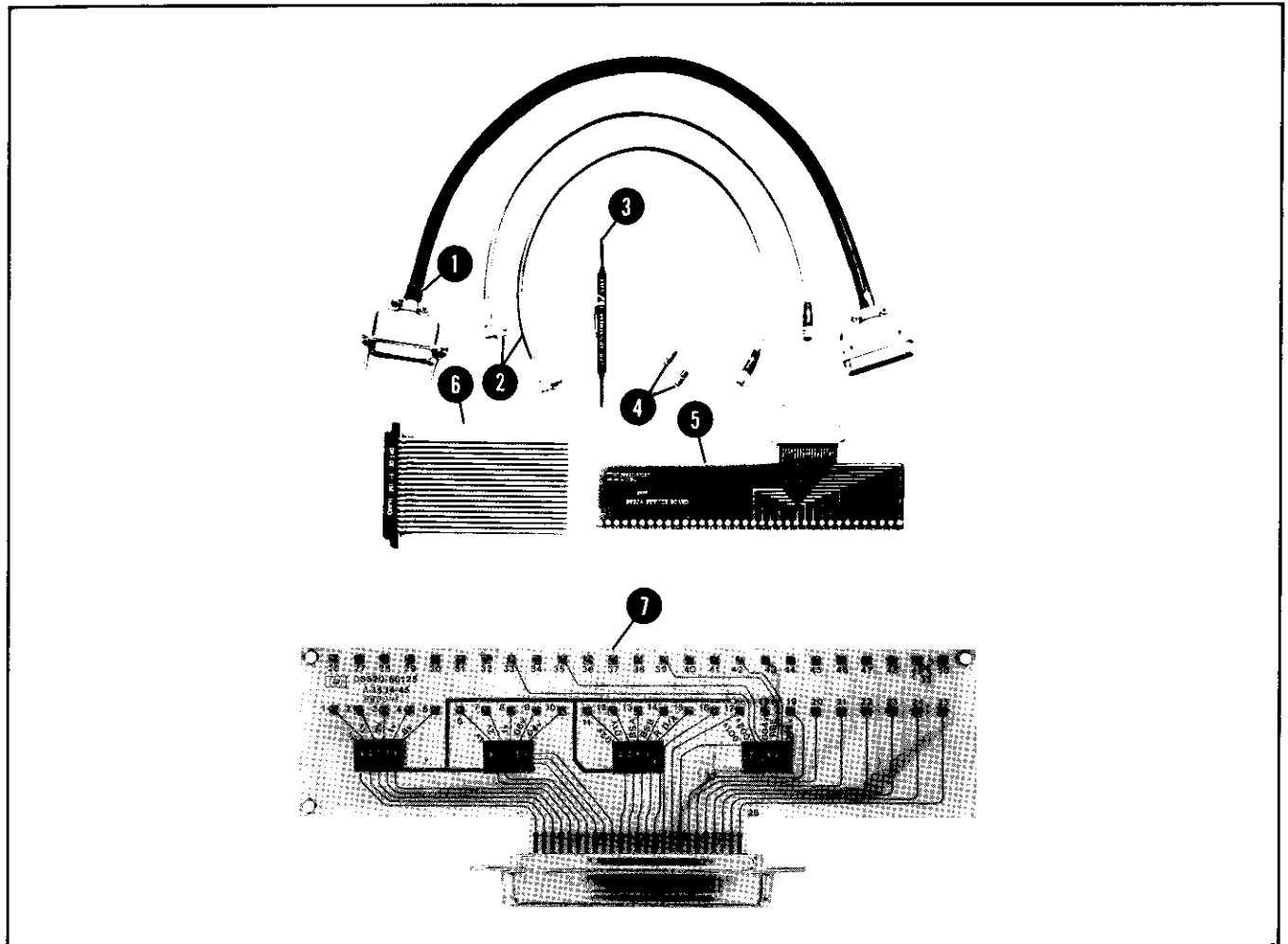

Item	Name	Part No.	Use
1	Extender Cable	08620-60032	Moves RF Plug-in outside mainframe for alignment or service.
2	RF Service Cable (2 each)	8120-1578	Allows troubleshooting RF circuits.
3	Adjustment Tool	8830-0024	Fits miniature adjustment slot on potentiometers.
4	RF Connector, straight adapter. SMA jack to SMA jack (2 each)	1250-1158	Adapts RF Service cables from plug to jack.
5	36-Pin Service Board	08620-60037	Allows probing RF Section interface connector, or rear-panel programming connector on all mainframes except 8620C, during performance testing or troubleshooting of 8620 Series mainframes.
6	18-Pin Extender Board	5060-2041	Extends mainframe boards for troubleshooting.
7	50-Pin Service Board	08620-60125	Allows probing rear-panel programming connector during performance testing or troubleshooting of HP Model 8620C Sweep Oscillator mainframe.

Figure 1-3. Services Accessories Package, 08620-60124

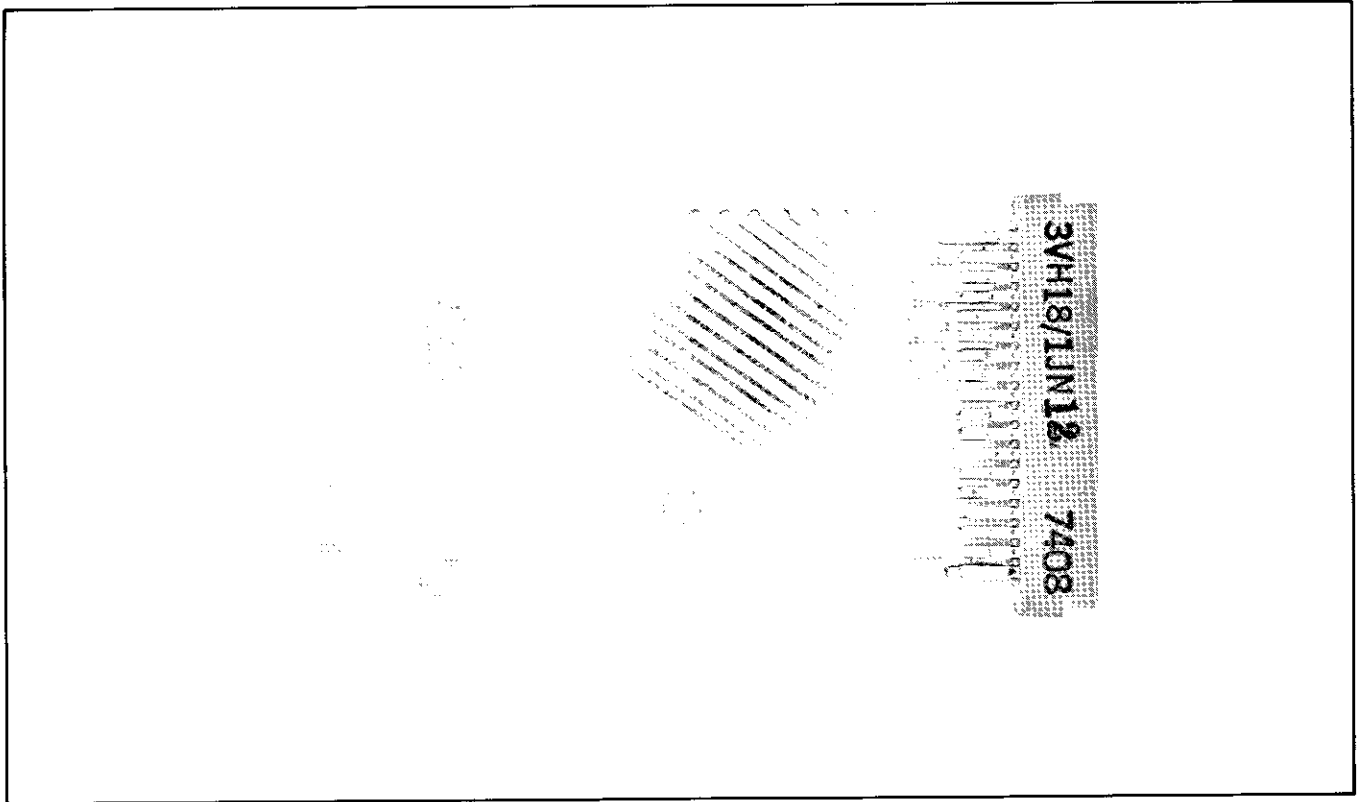

Figure 1-4. Reversing Extender Board, 86290-60033

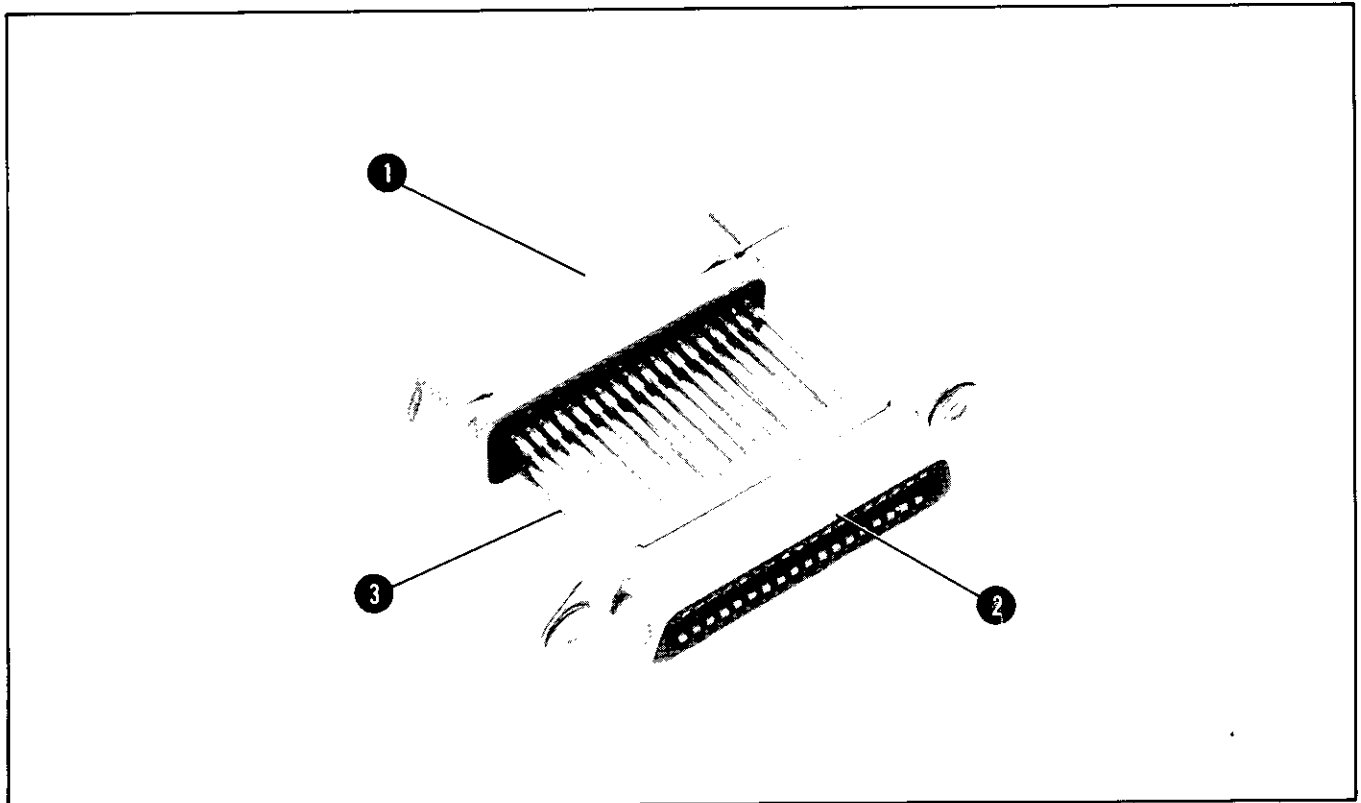

Figure 1-5. RF Section 36-Pin Extender, 08621-60056

SECTION II INSTALLATION

2-1. INTRODUCTION

2-2. This section provides installation instructions for the Model 86290A RF Plug-in and its accessories. This section also includes information about initial inspection and damage claims, preparation for using the RF Plug-in and packaging, storage and shipment.

2-3. INITIAL INSPECTION

2-4. Inspect the shipping container for damage. If the shipping container or cushioning material is damaged it should be kept until the contents of the shipment have been checked for completeness and the instrument has been checked mechanically and electrically. The contents of the shipment should be as shown in Figure 1-1. Procedures for checking electrical performance are given in Section IV. If the instrument combination does not pass the electrical performance tests, refer to the 86290A Adjustments (Section V) in this manual. If, after the 86290A Adjustments have been made, the instrument combination still fails to meet specifications, refer to mainframe Adjustments in the applicable mainframe manual. If a circuit malfunction is suspected, refer to troubleshooting procedures section of this manual or applicable mainframe manual. If the instrument does not pass the above electrical tests, or if the shipment contents are incomplete, or if there is mechanical damage or defect, notify the nearest Hewlett-Packard office. If the shipping container is damaged, or the cushioning material shows signs of stress, notify the carrier as well as the Hewlett-Packard office. Keep the shipping materials for carrier's inspection. The HP office will arrange for repair or replacement without waiting for claim settlement.

2-5. PREPARATION FOR USE

2-6. Power Requirements

2-7. When the Model 86290A RF Plug-in is properly installed, it obtains all power through the rear interface connector from the 8620 Series Sweep Oscillator mainframe.

2-8. Interconnections

2-9. For the Model 86290A Rf Plug-in to operate, it must be plugged into an 8620 Series mainframe. Connection is made by pushing the RF Plug-in into the mainframe so that the plug-in interface connector P1 mates with the mainframe connector.

2-10. Mating Connectors

2-11. All of the externally mounted connectors on the 86290A are listed in Table 2-1. Opposite each 86290A connector is an industry identification, the part number of a mating connector, and the part number of an alternate source for the mating connector.

2-12. Operating Environment

2-13. Temperature. The instrument may be operated in temperatures from 0°C to +55°C.

2-14. Humidity. The instrument may be operated in environments with humidity up to 95%. However, the instrument should also be protected from temperature extremes which cause condensation within the instrument.

2-15. Altitude. The instrument may be operated at altitudes up to 25,000 feet.

2-16. Frequency Scale Installation

2-17. To install frequency scale, proceed as follows:

- a. Disengage mainframe front-panel latch handle (Figure 3-2) and tilt front panel down.
- b. Depress BAND Lever until desired drum position is accessible from inside mainframe.

NOTE

If necessary to remove a frequency scale, exert a pressure OUTWARD, away from drum on right-hand edge of scale.

Table 2-1. Model 86290A Mating Connectors

86290A Connector		Mating Connectors	
Connector Name	Industry Identification	Part Number	Alternate Source
J1 RF OUTPUT	TYPE-N	1250-0882	Specialty Connector 25P117-2
J2 ALC EXT INPUT	BNC	1250-0256	Specialty Connector 28 P118-1
J3 SEQ SYNC	BNC	1250-0256	Specialty Connector 28 P118-1
J4 FM	BNC	1250-0256	Specialty Connector 28 P118-1
J5 FREQ REF	BNC	1250-0256	Specialty Connector 28 P118-1
J6 AUX OUT	TYPE-N	1250-0882	Specialty Connector 25P117-2

- c. Insert frequency scale so key (1/2-inch protrusion) fits into notch on left-hand side of drum. Then exert inward pressure on right-hand edge of frequency scale to snap it in place.

CAUTION

To prevent damage to frequency pointers when bandswitch drum is rotated, make certain that frequency scale is firmly in place and flush with band drum edges.

- d. Return front panel to upright position, and re-engage front-panel latch handle.

2-18. RF Plug-in Installation

2-19. To install 86290A RF Plug-in, proceed as follows:

- Press the 8620 Series mainframe LINE switch to OFF position.
- Position plug-in latch handle so rectangular cut-out is exposed to the front and slot is towards the rear.

- Slide plug-in into place towards rear of compartment.
- Drawer latch will start to move down when slot engages locking pin on mainframe.
- Press latch handle downward while still pushing in on RF Plug-in, until drawer latch is closed or flush with front panel.

2-20. Installation of Options

2-21. To install or remove an option, refer to the installation instructions in the appendices for the applicable option.

2-22. MODIFICATIONS

2-23. The 8620C mainframe is compatible with the 86290A RF Plug-in without modification. Unmodified 8620A mainframes, which include serial prefixes 1332A and below, will operate in CW and at slow sweep rates. The unmodified mainframes will not operate in fast sweep or with Band 4 selected on the mainframe. To modify 8620A mainframes with serial prefixes 1332A and below, order the 8620A Mainframe Modification Kit,

Option 060, HP Part Number 08620-60099. (See Table 1-3 for the description of the kit.)

2-24. All 8620B mainframes will operate with the 86290A RF Plug-in in CW and slow sweep rates; however, some specifications in Table 1-1 do not apply. A modification of all 8620B mainframes is required if all capabilities of the 86290A are to be realized. To modify the 8620B, order the 8620B Mainframe Modification Kit, HP Part Number 08620-60100.

2-25. STORAGE AND SHIPMENT

2-26. Environment

2-27. The instrument may be stored or shipped in environments within the following limits:

Temperature -40°C to +75°C
 Humidity Up to 95%
 Altitude Up to 25,000 feet

The instrument should also be protected from temperature extremes which cause condensation within the instrument.

2-28. Packaging

2-29. Original Packaging. Containers and materials identical to those used in factory packaging are available through Hewlett-Packard offices. If the instrument is being returned to Hewlett-

Packard for servicing, attach a tag indicating the type of service required, return address, model number, and full serial number. Also, mark the container FRAGILE to assure careful handling. In any correspondence, refer to the instrument by model number and full serial number.

2-30. Other Packaging. The following general instructions should be used for re-packaging with commercially available materials:

- a. Wrap instrument in heavy paper or plastic. (If shipping to Hewlett-Packard office or service center, attach tag indicating type of service required, return address, model number, and full serial number.)
- b. Use strong shipping container. A double-wall carton made of 350-pount test material is adequate.
- c. Use enough shock-absorbing material (3-to 4-inch layer) around all side of instrument to provide firm cushion and prevent movement inside container. Protect control panel with cardboard.
- d. Seal shipping container securely.
- e. Mark shipping container FRAGILE to assure careful handling.
- f. In any correspondence, refer to instrument by model number and full serial number.

SECTION III OPERATION

3-1. INTRODUCTION

3-2. This operating section explains the function of the controls and indicators of the Model 86290A RF Plug-in. It describes typical operating modes in a measurement system and covers operator maintenance for replacing the indicator lamps. Figure 3-13 shows the positions of the ALC Function switch AIS1 that the operator will set for each application.

3-3. PANEL FEATURES

3-4. Front and rear panel features are described in Figures 3-2 and 3-3. Description numbers match the numbers on the illustration.

3-5. OPERATOR'S CHECKS

3-6. The Operator's Checks (Figure 3-4) allow the operator to make quick evaluation of the instrument's main functions prior to use. These checks assume that the 86290A RF Plug-in is installed in an 8620C Sweep Oscillator mainframe. The checks cover the RF Plug-in and mainframe; therefore, if the correct indications are not obtained, trouble may be in either of the units. If the RF Plug-in is suspected, perform applicable performance tests in Section IV of this manual, and if necessary, the related adjustments in Section V. If correct indications are still not obtained, refer to the troubleshooting chart in Section VIII to isolate the problem.

3-7. OPERATING INSTRUCTIONS

WARNING

Any interruption of the protective (grounding) conductor (inside or outside the instrument) or disconnecting the protective earth terminal could make this instrument dangerous.

3-8. Internal Leveling

3-9. The most convenient method of RF output leveling is internal leveling. A portion of the RF output is coupled from a Directional Coupler DC1 to a Detector CR1. A proportional dc-voltage is applied to an operational amplifier in the 86290A ALC Amplifier Assembly A1. The Operator's Checks in Figure 3-4 are performed in the internal leveling mode.

3-10. External Power Meter Leveling

3-11. Power leveling can be obtained with a power meter and power splitting tee or directional coupler as shown in Figure 3-10. A sample of the RF output signal is routed to a power meter to produce a dc voltage proportional to the RF signal level. The dc voltage is applied to the 86290A ALC circuits and compared with an internal reference voltage. A difference voltage is produced and amplified by the ALC amplifier before being applied, as modulator drive, to the Coupler/Modulator assembly A10. The modulator drive controls the output of the Coupler/Modulator to maintain a constant power level.

3-12. External Crystal Detector Leveling

3-13. Power may be leveled externally using a power splitting tee (or directional coupler) and crystal detector. This leveling system uses a power splitting tee to sample the RF output signal and a crystal detector to produce a dc voltage proportional to RF signal level. The detector voltage is compared with an internal reference voltage, and the difference voltage changes the output power level to keep it constant at the output. Instead of a power splitting tee, a directional coupler may be used to sample the RF signal for the leveling loop. Directional couplers are usually narrow band, whereas the power splitting tee is flat over a wide frequency range. The advantage of a directional coupler is that it does not have a 6-dB loss like the power splitting tee, therefore a higher maximum leveled power output may be obtained. To place the crystal detector leveling loop in operation, use the test setup and procedures in Figure 3-11.

3-14. Internal AM

3-15. The 8620 Series Sweep Oscillator mainframes have an internal 1 kHz square wave for internal amplitude modulation of the RF signal. This provides an ON/OFF ratio of >25 dB for all bands of the 86290A.

3-16. External AM

3-17. The 86290A RF Output (CW) signal can be amplitude modulated from 0 to 100% using an external modulating signal applied to the mainframe EXT AM connector. This provides an ON/OFF ratio of >30 dB for all bands of the 86290A. A positive 5 volts input reduces the RF power output to at least 30 dB below specified maximum power.

3-18. External FM

3-19. The 86290A RF Output signal can be frequency modulated using an external modulating signal applied to the 86290A FM Input connector. The external FM function provides a means of obtaining an output frequency that varies under the control of an external modulation signal. A positive going voltage causes output frequency to decrease while a negative going voltage causes output frequency to increase.

3-20. Frequency Reference

3-21. A sweep signal output is available at the rear-panel **FREQ REF** connector J5 for phase-locking external equipment. The sweep signal is approximately $1\text{V}/\text{GHz}$.

3-22. Phase-Lock Operation

3-23. The 86290A RF Output (CW) signal may be phase-locked using an external phase-lock signal applied to the 86290A FM Input connector. The phase-lock function provides a means of obtaining a very stable CW frequency by transferring the frequency stability of the reference oscillator to the source. If the CW frequency starts to drift, the phase difference between the CW frequency and the reference frequency (reference oscillator) is detected, producing a dc voltage. The dc voltage is a correction signal which restores the CW frequency to its previous point. Stability of this CW frequency is determined by the stability of the reference oscillator.

3-24. X-Y Recorder Operation

3-25. In Sequential Sweep operation (Band 4), the power output of the 86290A goes to zero at

each switchpoint for a brief time interval. This is approximately 6 ms between Band 1 and 2 and approximately 8 ms between Bands 2 and 3. (See Section VIII for a complete explanation of Sequential Sweep operation.)

3-26. When an X-Y Recorder is used to plot the detected RF amplitude from the 86290A, the recorder's frequency response is not adequate to respond fully to this "zero-power" interval and will indicate a small negative going spike only. The width of this spike is a function of sweep speed, and is essentially zero for sweep times greater than 20 seconds.

3-27. Recorders without DELAY MUTE capability will display the "zero-power" spikes at each switchpoint and is unavoidable. However, information loss due to the spikes can be eliminated by using a slow enough sweep time (>20 sec). Recorders with DELAY MUTE capability can be operated so that "zero-power" spikes are eliminated. This is accomplished by connecting the 86290A SEQ SYNC rear-panel output to the X-Y Recorder DELAY MUTE input. Using this DELAY MUTE feature will give a "glitch" free plot for test devices which have relatively flat responses at the switch point frequencies. However, test devices having a rapid rate of change across a switch point, such as the Band Pass filter illustrated in Figure 3-1, may still show a slight "glitch." Since it may not be immediately apparent that the "glitch" is due to the test setup rather than the device under test, it is recommended that a reference plot be made using the X-Y Recorder PEN LIFT input whenever "glitches" appear in the test device output near the 6.2 GHz and 12.4 GHz switch-point frequencies. The PEN LIFT Input will not affect the switch-points, therefore this can be easily recognized. This is illustrated in Figure 3-1.

3-28. Retrace time of the 8620 Series mainframe, when using an 86290A, is much faster than sweep time. When RF Blanking is used, 86290A power output goes to zero during retrace. If an X-Y Recorder is being used, the recorder pen will not be able to go to "zero-power" as rapidly as the 86290A. Therefore, the retrace line on the X-Y Recorder will not resemble actual RF response. This can be improved by placing the mainframe rear-panel RF BLANKING/OFF switch in the OFF position. If a "zero-power" reference line is desired, one may be drawn by triggering a single sweep with 86290A power off (front-panel RF ON-OFF switch OFF).

*change
page 172*

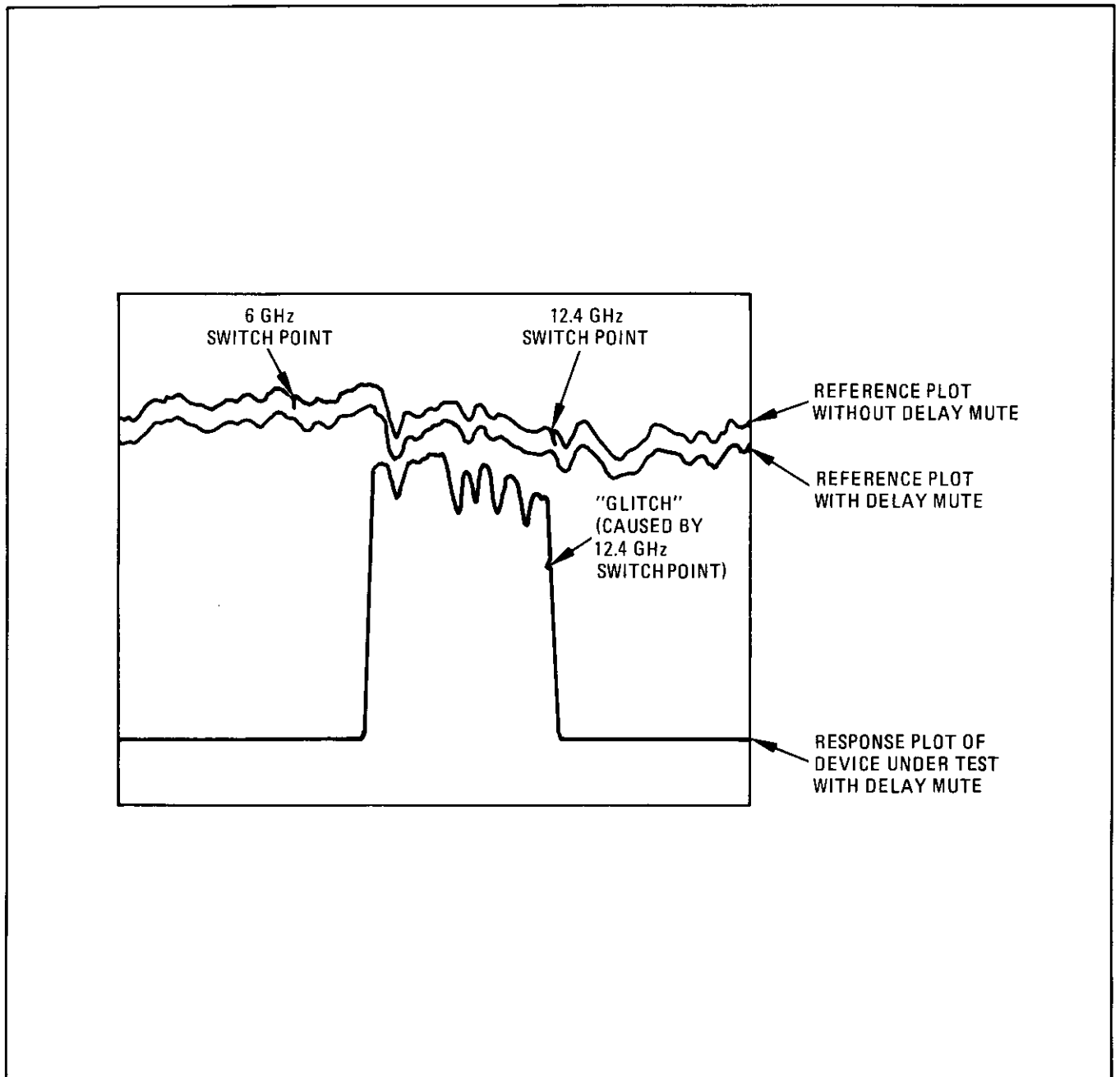

Figure 3-1. Typical Recorder Plot of Device Under Test and Reference Plots

3-29. X-Y RECORDER MODIFICATION KIT

3-30. A modification kit is available to convert older X-Y Recorders to obtain DELAY MUTE capability. See the X-Y Recorder Operating and Service Manual or contact your nearest Hewlett-Packard Office for part number information.

3-31. OPERATOR'S MAINTENANCE

3-32. Operator maintenance on the 86290A consists of replacing defective front panel Band indicator lamps. Removal and replacement procedures are contained in Figure 3-13.

3-33. Replacement of the UNLEVELED lamp is shown in Section VIII as a maintenance procedure. (See Figure 8-9.)

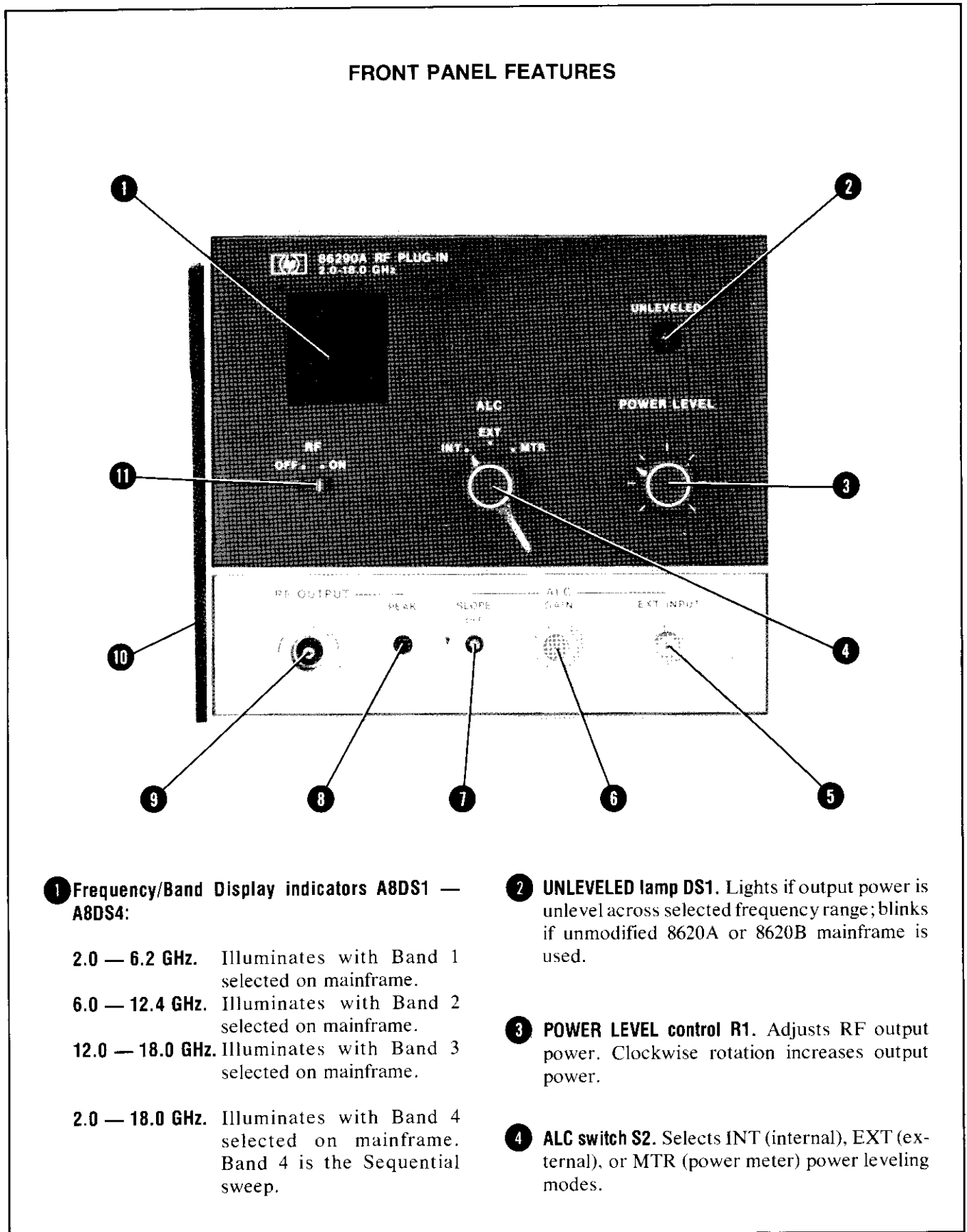

Figure 3-2. Front Panel Controls, Connectors and Indicators (1 of 2)

FRONT PANEL FEATURES

- 5 **ALC EXT INPUT BNC connector J2.** Input for external leveling from power meter or crystal detector.
- 6 **ALC GAIN control R4.** Adjusts ALC leveling amplifier gain when system is using an external leveling loop. Clockwise rotation increases ALC loop gain.
- 7 **ALC SLOPE-OFF control R3.** Compensates for high frequency power losses in external RF cables by attenuating power at lower frequencies. This compensation provides a flat RF signal output. The OFF Position removes all compensation.
- 8 **RF OUTPUT PEAK control R2.** Optimizes RF output power for selected frequency range and assures minimum harmonically related signals.
- 9 **RF OUTPUT connector J1.** Type-N 50-ohm RF output connector.
- 10 **Drawer Latching Handle.** Aids in installing and removing RF Plug-in. After installing, handle locks to hold RF Plug-in in place.
- 11 **RF ON-OFF switch S1.** Turns RF power on and off. This is useful when zeroing a power meter or establishing a zero power reference on an X-Y recorder.

Figure 3-2. Front Panel Controls, Connectors and Indicators (2 of 2)

change post 7-2

replaced fig. 3-3 with fig. 7-19, page 7-22

REAR PANEL FEATURES

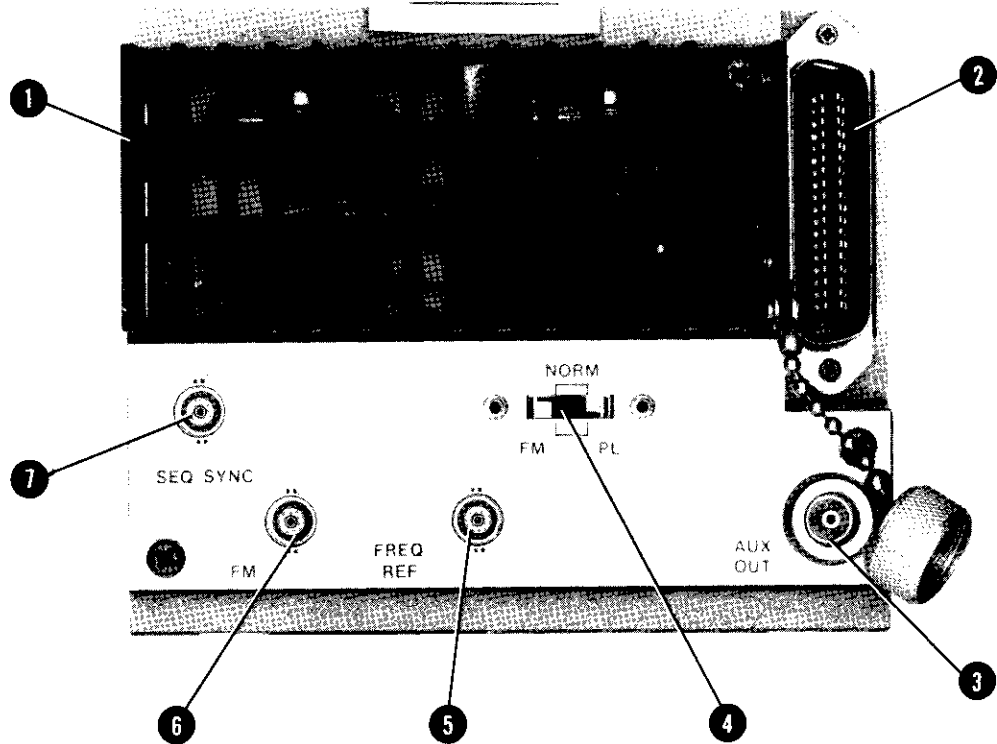

- 1 **Rear Panel Heatsink.** Provides heat dissipation and mounting for YTM and YTO coil-driver transistors Q1 and Q2, and reference resistors R5 and R6.
- 2 **Interface Connector P1.** Provides interconnection between 8620 Series mainframe and 86290A RF Plug-in.
- 3 **AUX OUT J6.** Provides YIG-tuned Oscillator RF output signal of 2.0 — 6.2 GHz. (Cover provided should be installed when AUX OUT not used.)
- 4 **FM-NORM-PL switch S3.** Operates in conjunction with FM input connector to provide op-

timum performance for either normal sweep (NORM), frequency modulation (FM), or phase-lock (PL) operation. If FM or PL modes of operation are not being used, switch should be in NORM.

- 5 **FREQ REF BNC connector J5.** Provides approximately #1 volt/GHz ramp signal output. *change post 7-2* *OUTPUT BNC connector JS*
- 6 **FM BNC connector J4.** Input connector for FM modulation signal or phase-locking error signal.
- 7 **SEQ SYNC connector J3.** Provides RF blanking output for timing signal to external equipment.

Figure 3-3. Rear Panel Connectors and Switch

OPERATOR'S CHECKS

FRONT

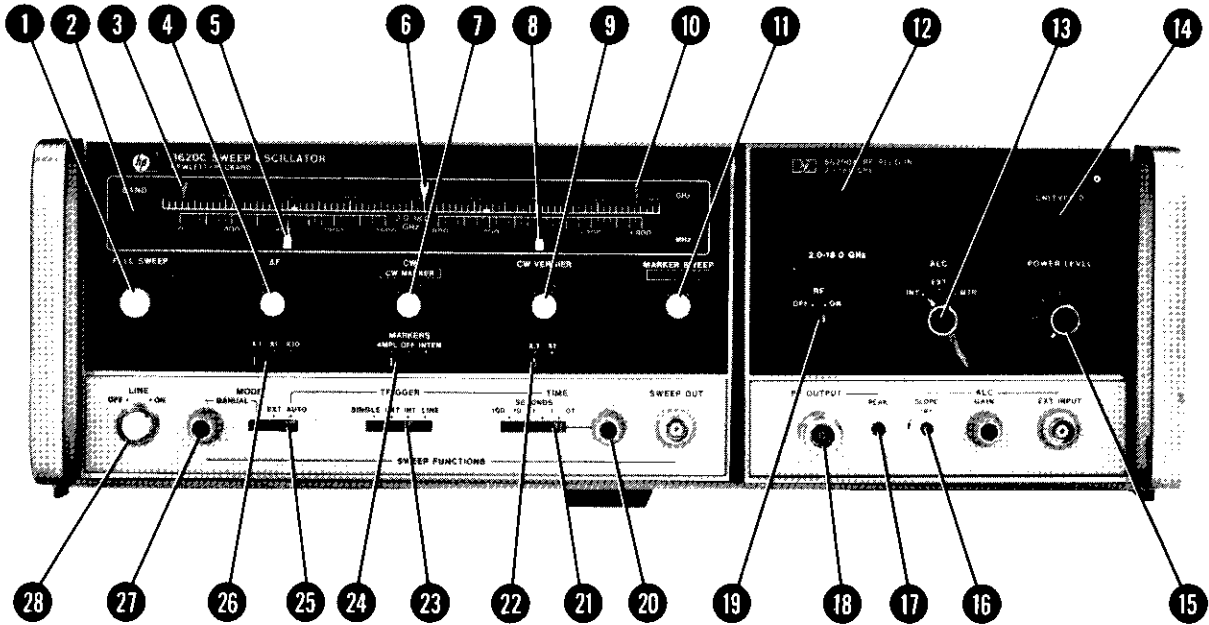

REAR

*change page 7-2
Replaced fig 3-4 (REAR) with fig. 7-14, page 7-7*

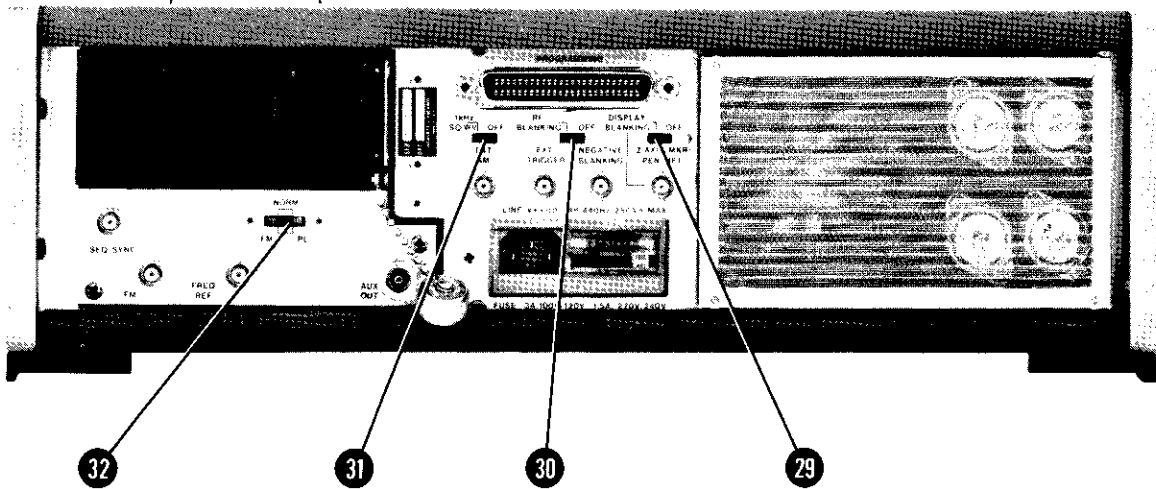

Figure 3-4. Operator's Checks (1 of 4)

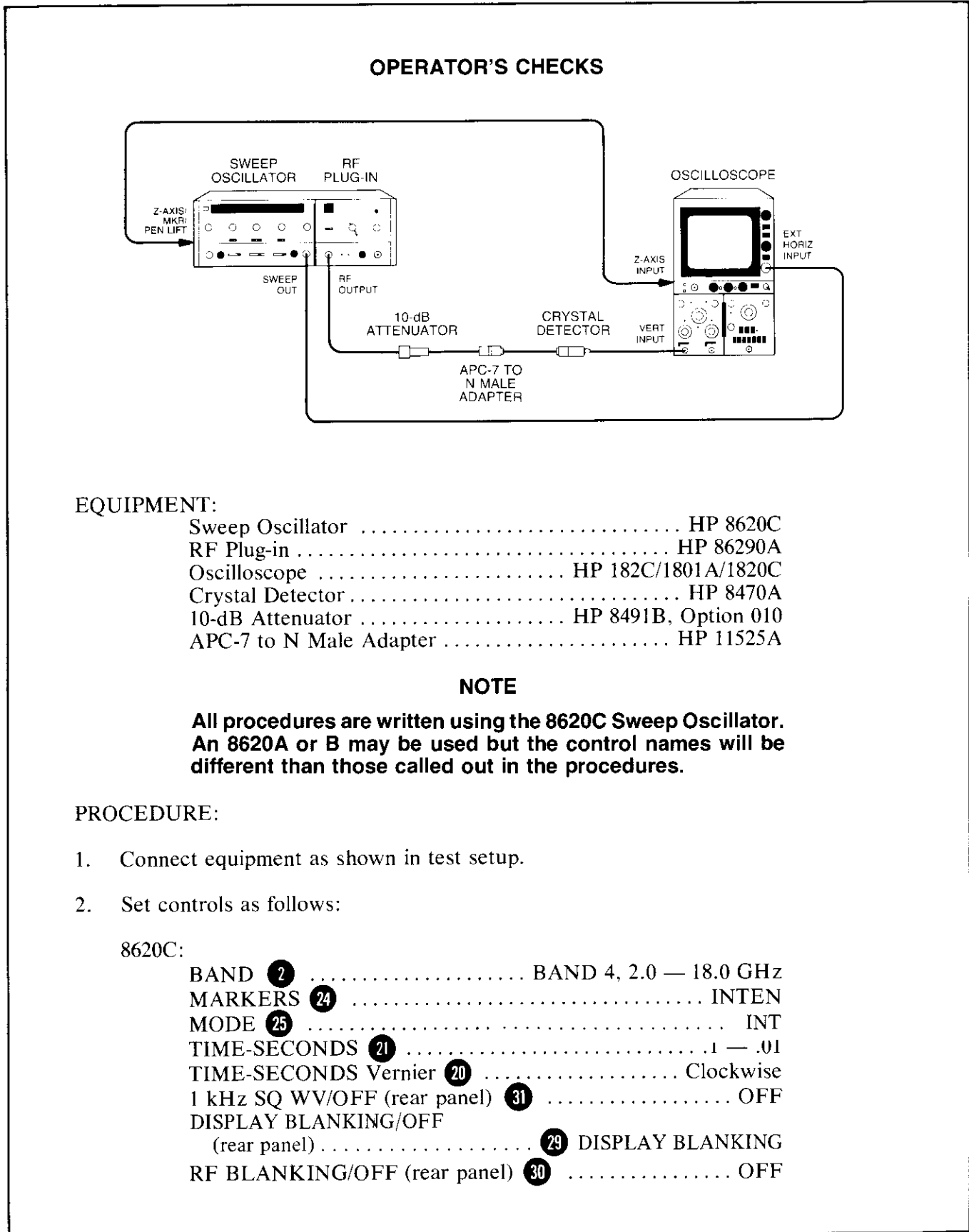

Figure 3-4. Operator's Checks (2 of 4)

OPERATOR'S CHECKS

86290A:

RF OUTPUT 18 19 ON
 POWER LEVEL 15 Fully clockwise
 ALC 13 INT
 SLOPE-OFF 16 OFF
 FM-NORM-PL (rear panel) 32 NORM (Normal)

3. Press LINE pushbutton. switch 28 to ON; LINE 28, and FULL SWEEP 1 pushbuttons should light. The 2.0 — 18.0 GHz lamp 12 should light on 86290A.

NOTE

If the 2.0 — 18.0 GHz lamp blinks ON and OFF, this indicates the use of a mainframe which needs to be modified to operate in Sequential sweep. See Modifications in Paragraph 2-22. If an unmodified mainframe is being used, the operator's Checks may be continued using Band 3.

4. Check that the instrument is sweeping correctly. This is indicated by a continuous signal-level line below zero-volt dc level on oscilloscope. Adjust PEAK control 17 for maximum signal on oscilloscope.
5. UNLEVELED light 14 may be lit. If UNLEVELED light is lit, reduce output power by turning 86290A POWER LEVEL control 15 counterclockwise until UNLEVELED Light goes out. This is adjustment point for maximum leveled power. Oscilloscope trace should be leveled. (Refer to Figures 3-5 and 3-6 for typical oscilloscope display of Sequential Sweep unlevelled and leveled RF Power Output. Refer to Figures 3-7 and 3-8 for single-band displays.)
6. Set 8620C MARKERS switch 24 to INTEN position and markers should appear on oscilloscope trace as bright dots. Adjust oscilloscope intensity for best contrast. Set MARKERS switch to AMPL position and markers should appear on oscilloscope trace as pips.
7. Set 8620C MODE switch 25 to MANUAL position and slowly adjust MANUAL control 27. Trace dot should move across oscilloscope. Return 8620C MODE switch to AUTO.
8. Press 8620C CW pushbutton 7; pushbutton should light and trace on oscilloscope should be a dot. Change frequency 7 with CW MARKER control and dot should move across oscilloscope.

Figure 3-4. Operator's Checks (3 of 4)

OPERATOR'S CHECKS

9. Press 8620C CW VERNIER pushbutton switch **9** and pushbutton should light. Adjusting CW VERNIER control moves white pointer **8** above CW VERNIER control and dot on oscilloscope should also move across CRT at a very slow rate and through a narrow range. CW VERNIER slide switch **22** selects a 0.1 multiplier (X.1 position) for CW vernier scale; in X1 position, scale is read directly. Press 8620C CW pushbutton; CW VERNIER pushbutton lamp should turn off.
10. Press 8620C ΔF pushbutton **4**; ΔF and CW **7** pushbuttons should be lit. Deviation from CW frequency is selected by ΔF control, and adjusting it moves white pointer **5** above ΔF control. ΔF slide switch **26** selects a 0.1 multiplier (X.1 position), a 1.0 multiplier (X1 position), or a 10 multiplier (X10 position).
11. Adjust POWER LEVEL control **15** fully clockwise. Adjust 8620C ΔF control **4** between zero and maximum. Sweep trace should be displayed on oscilloscope and should change as ΔF control is adjusted.

Figure 3-4. Operator's Checks (4 of 4)

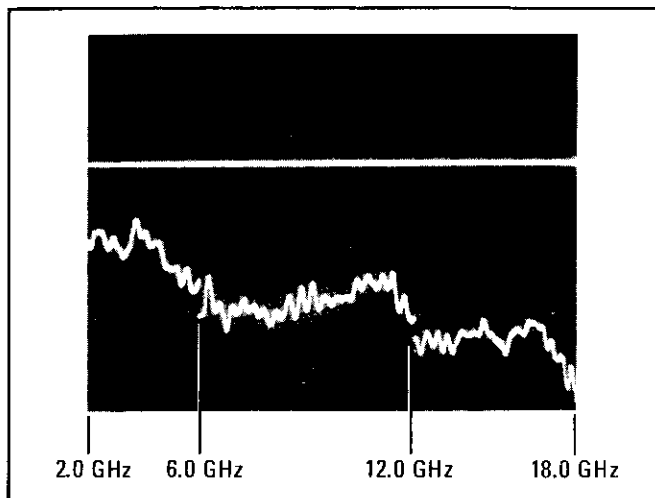

Figure 3-5. Unlevelled Rf Power Output for Sequential Sweep

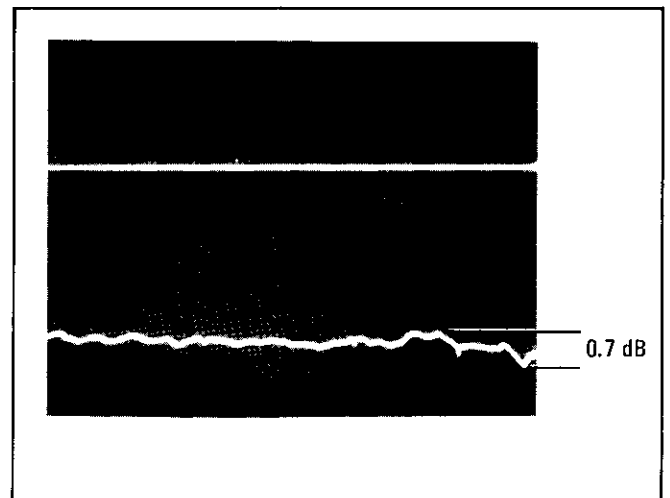

Figure 3-6. Leveled RF Power Output for Sequential Sweep

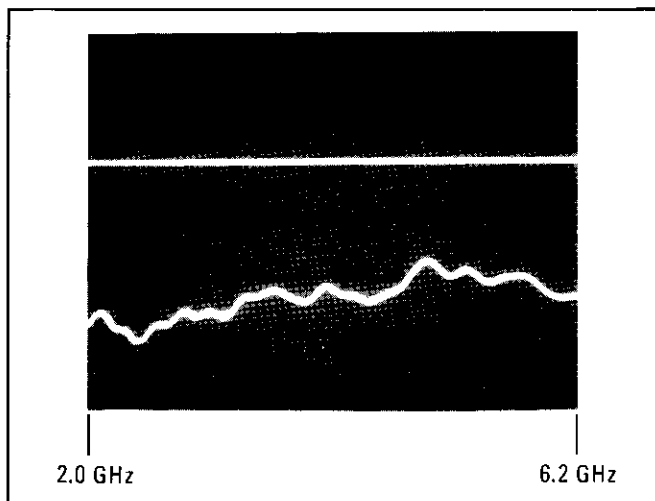

Figure 3-7. Unlevelled RF Power Output for Single Band

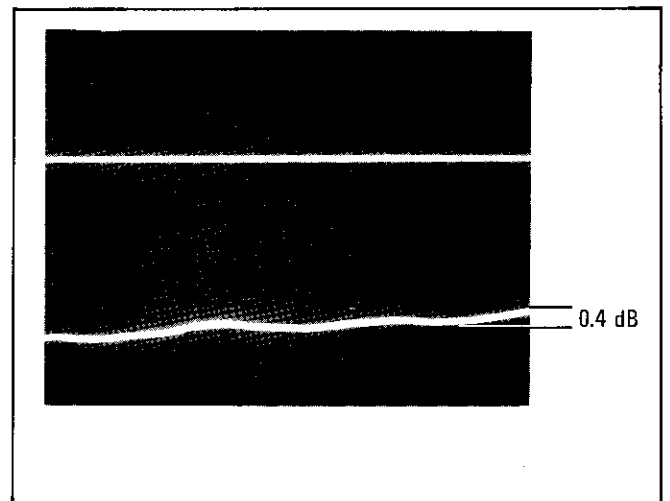

Figure 3-8. Leveled RF Power Output for Single Band

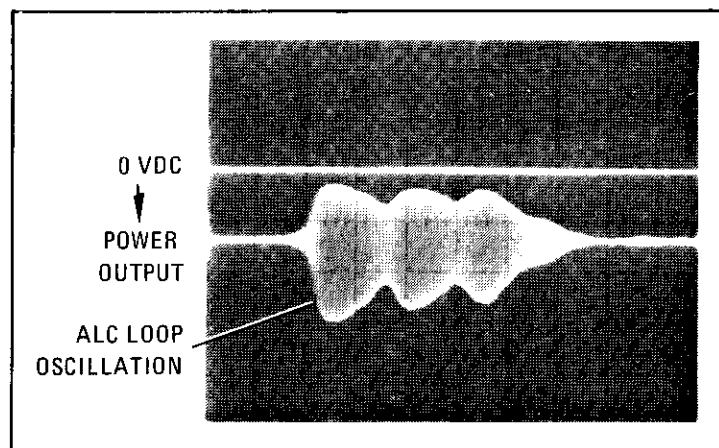
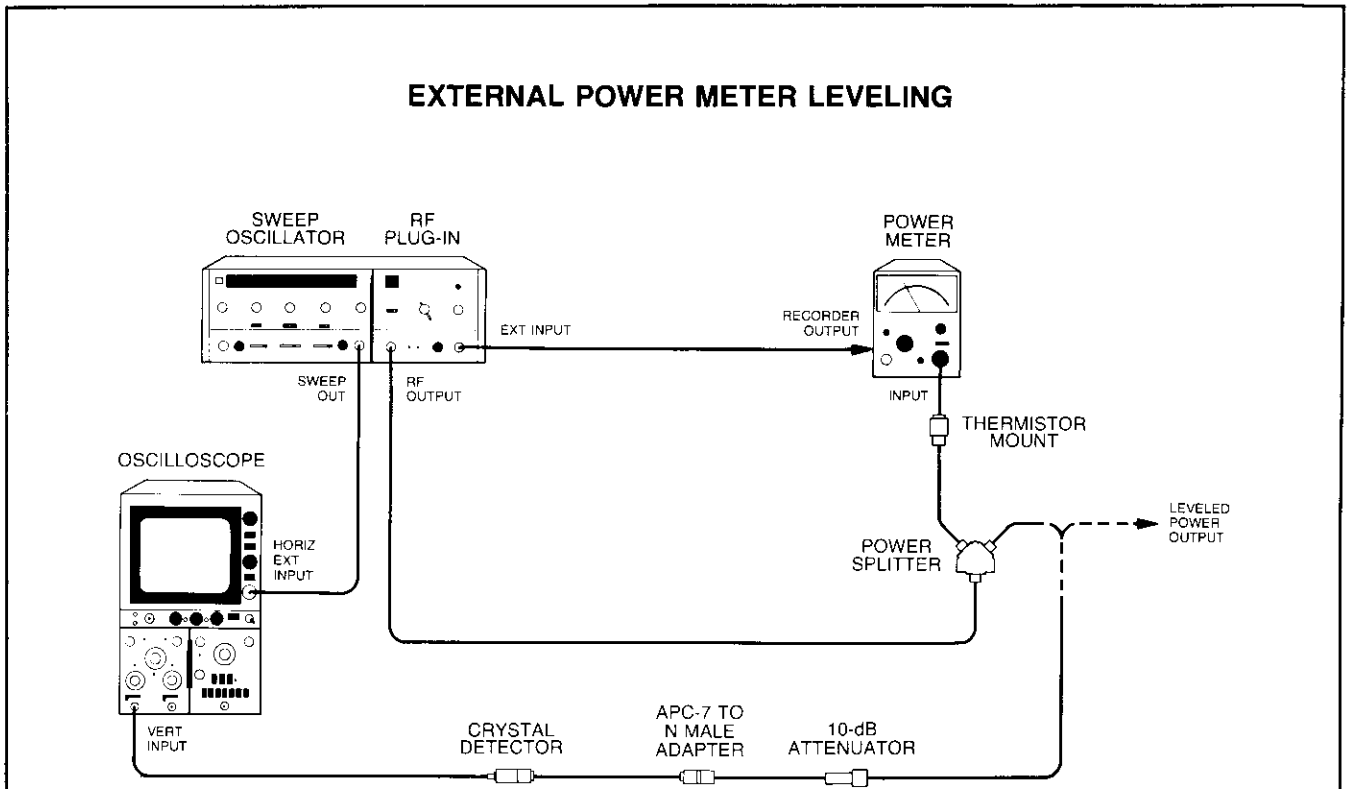

Figure 3-9. Oscillations with ALC Loop Gain Too High



EQUIPMENT:

Sweep Oscillator	HP 8620C
RF Plug-in	HP 86290A
Oscilloscope	HP 182C/1801A/1820C
Power Meter	HP 432A
Thermistor Mount	HP 8478B
Crystal Detector	HP 8470A
APC-7 to N Male Adapter	HP 11525A
10-dB Attenuator	HP 8491B, Option 010
Power Splitter	HP 11667A

NOTE

Power meter leveling should be used at slowest sweep rates. Leveling is limited by response time of thermistor mount

PROCEDURE:

1. Connect equipment as shown in test setup.

Figure 3-10. External Power Meter Leveling (1 of 2)

EXTERNAL POWER METER LEVELING

- Set controls as follows:

8620C:

BAND BNAD 4, 2.0 — 18.0 GHz
 MARKERS OFF
 MODE AUTO
 TRIGGER INT
 TIME-SECONDS 100 — 10
 TIME-SECONDS Vernier Fully clockwise
 1 kHz SQ WAVE/OFF (rear panel) OFF
 DISPLAY BLANKING/OFF (rear panel) . . DISPLAY BLANKING

86290A:

RF OUTPUT ON
 POWER LEVEL Fully clockwise
 ALC MTR (Power Meter)
 ALC-GAIN Fully counterclockwise
 FM-NORM-PL (rear panel) NORM (Normal)

- Press 8620C LINE pushbutton to ON; LINE and FULL SWEEP pushbuttons should light, indicating FULL SWEEP sweep mode is selected. The 2.0 — 18.0 GHz lamp should light on 86290A.
- Select range on power meter to obtain indication near top 1/3 of meter scale.
- Adjust 86290A ALC GAIN control clockwise until leveling across band occurs as shown in Figure 3-6. If trace is not leveled or is only partially leveled (as shown in Figure 3-5) with ALC GAIN fully clockwise, reduce RF OUTPUT power. This is done by adjusting POWER LEVEL control counterclockwise until leveling occurs as shown in Figure 3-6. If oscillations appear on trace as shown in Figure 3-9, turn ALC GAIN control counterclockwise. With proper leveling across the band, the 86290A UNLEVELED light should be out.
- To use leveled RF Power output for testing external equipment, make connection at point marked "Leveled Power Output."

Figure 3-10. External Power Meter Leveling (2 of 2)

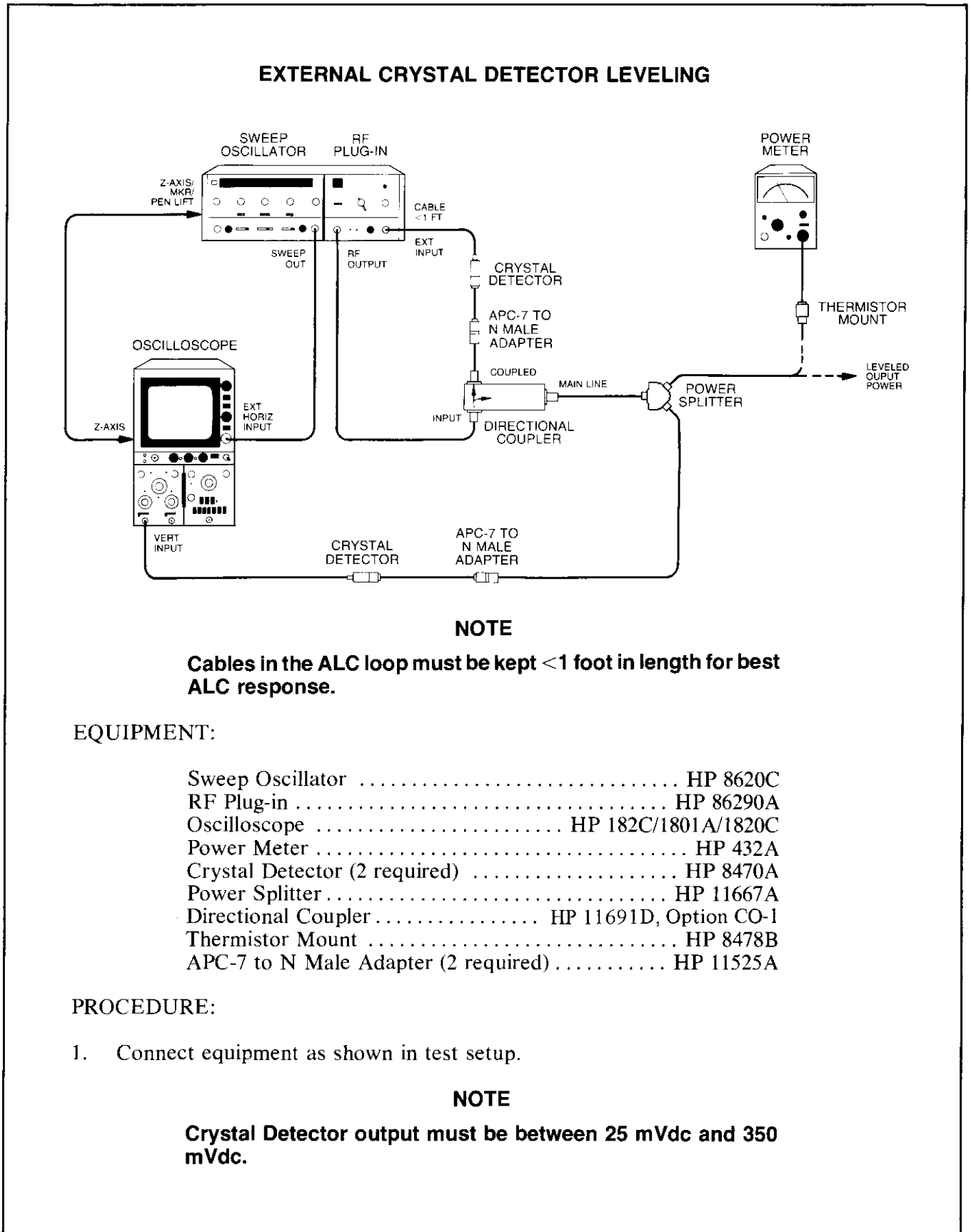

Figure 3-11. External Crystal Detector Leveling (1 of 2)

EXTERNAL CRYSTAL DETECTOR LEVELING

2. Set controls as follows:

8620C:

BAND BAND 4, 2.0 — 18.0 GHz
 MARKER OFF
 MODE AUTO
 TRIGGER INT
 TIME/SECONDS Vernier Fully clockwise
 1 kHz SQ WAVE/OFF (rear panel) OFF
 DISPLAY BLANKING/OFF (rear panel) . . DISPLAY BLANKING

86290A:

RF OUTPUT ON
 POWER LEVEL Fully clockwise
 ALC EXT
 ALC GAIN Fully clockwise
 FM-NORM-PL (rear panel) NORM (Normal)

3. Press 8620C LINE pushbutton to ON; LINE, and FULL SWEEP pushbuttons should light, indicating FULL SWEEP mode is selected. The 2. — 18.0 GHz lamp should light on 86290A.
4. Adjust ALC GAIN and POWER LEVEL controls fully clockwise for maximum RF power OUTPUT and maximum ALC Loop gain. Adjust PEAK control for maximum RF power. One of the conditions shown in Figures 3-5 through 3-9 should be displayed on oscilloscope. If trace is unleveled as shown in Figures 3-5 or 3-7 (or partially leveled) and UNLEVELED lamp is on, turn POWER LEVEL control counterclockwise until trace is level. (See Figures 3-6 and 3-8). If ALC loop gain is too high, oscillations may occur as shown in Figure 3-9. To remove oscillations, reduce ALC loop gain by turning ALC GAIN control counterclockwise.
5. To use leveled RF power output for testing external equipment, make connection at point marked "Leveled Power Output."

Figure 3-11. External Crystal Detector Leveling (2 of 2)

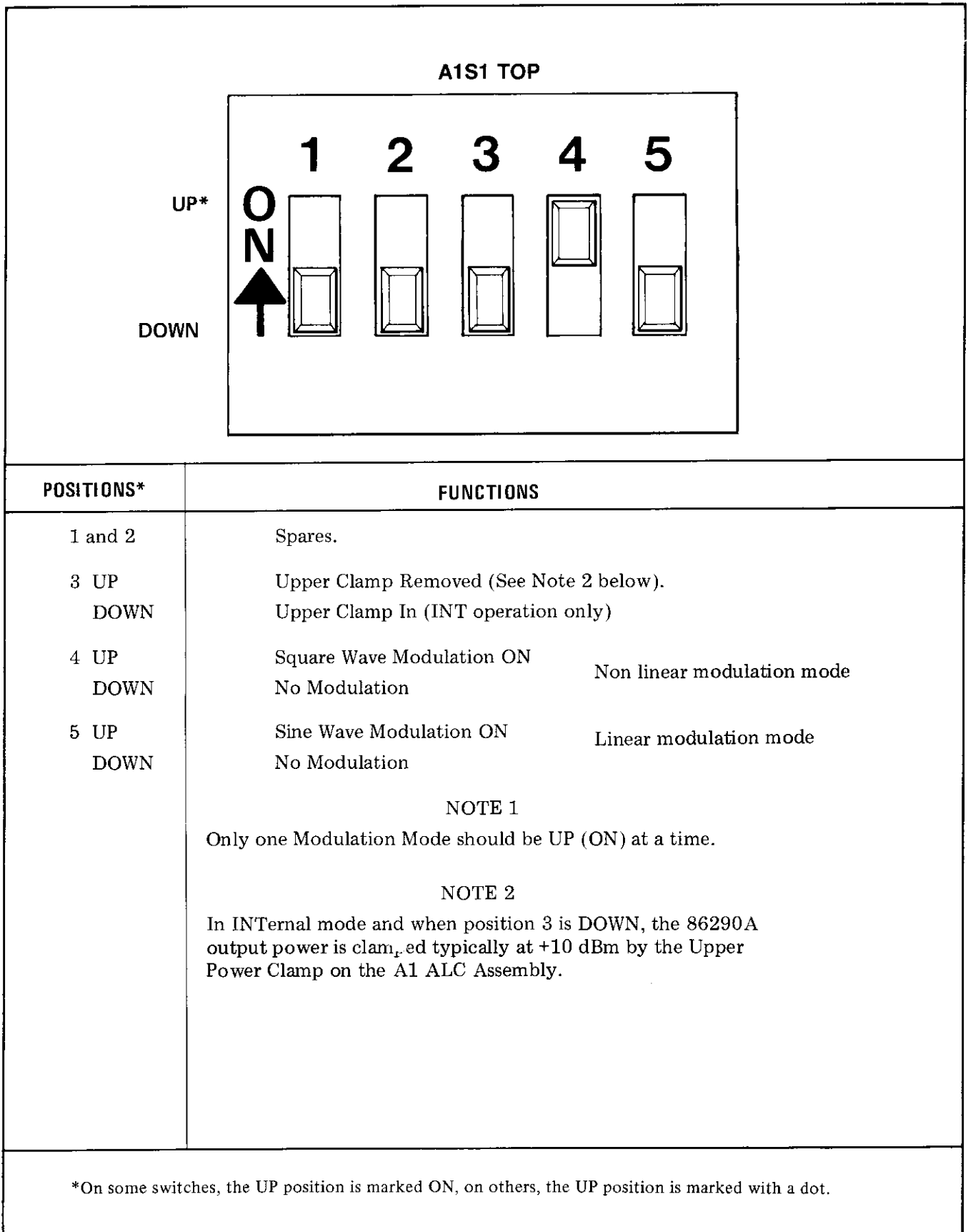

Figure 3-12. Switch Positions and Functions for ALC Function Switch A1S1

BAND INDICATOR LAMP REPLACEMENT

1. Press mainframe LIN switch to OFF position.
2. Remove 86290A RF Plug-In from mainframe.
3. Remove front panel:
 - a. Disconnect cable W10 from RF OUTPUT connector J1.
 - b. Remove Drawer Latch Handle **5** by removing screw **3** and latch spring **2**. Note position of spring **2** and location of hole **1** for reinstalling.
 - c. Remove four screws **4** from front panel (two on each side).
 - d. Pull front panel out of frame slightly and remove connector J7 from A7 Master Board.
4. Remove and replace lamp:
 - a. Lift contact spring **6** slightly and rotate it to expose base of lamp, (A8DS1-A8DS4). Remove old lamp.

NOTE

Lifting the contact spring too far may bend it, reducing spring tension.

- b. Install new lamp and replace contact spring **6** over base.
5. Install front panel by reversing instructions in step 3.

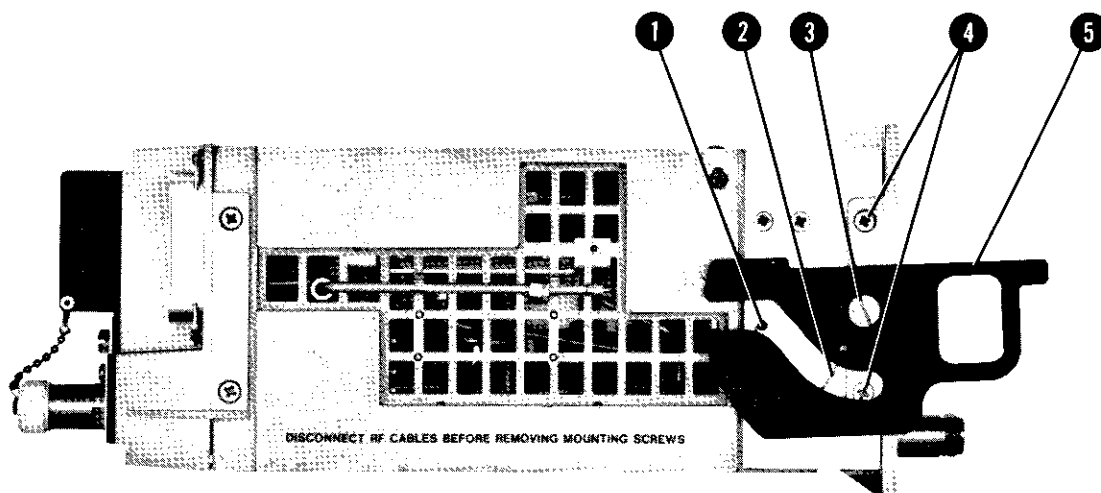

Figure 3-13. Band Indicator Lamp Replacement (1 of 2)

BAND INDICATOR LAMP REPLACEMENT (Cont'd)

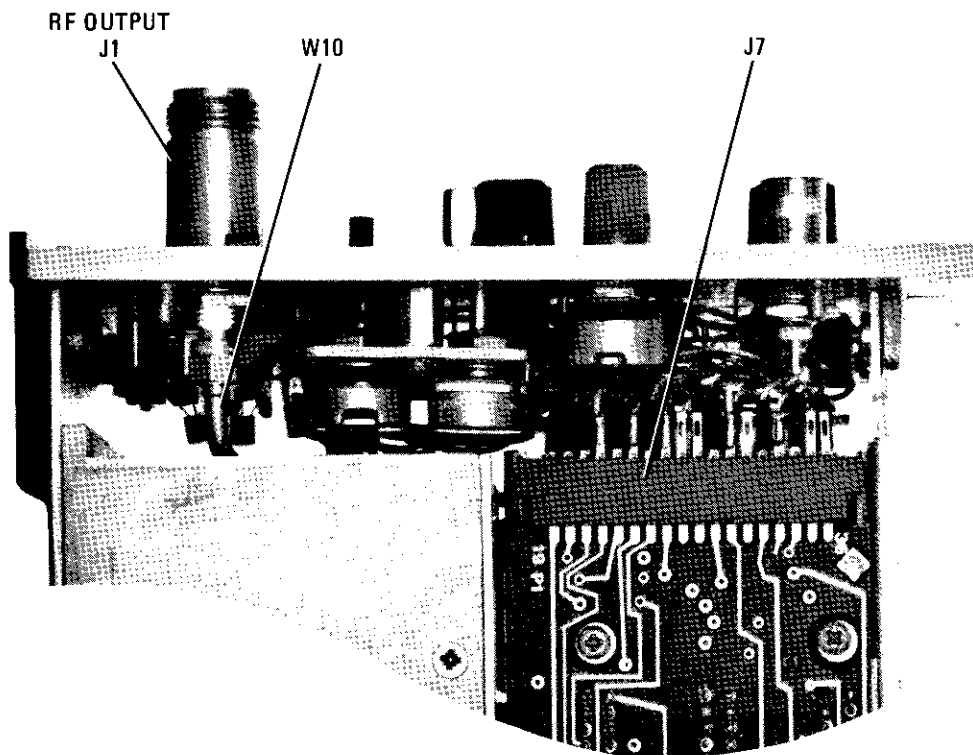
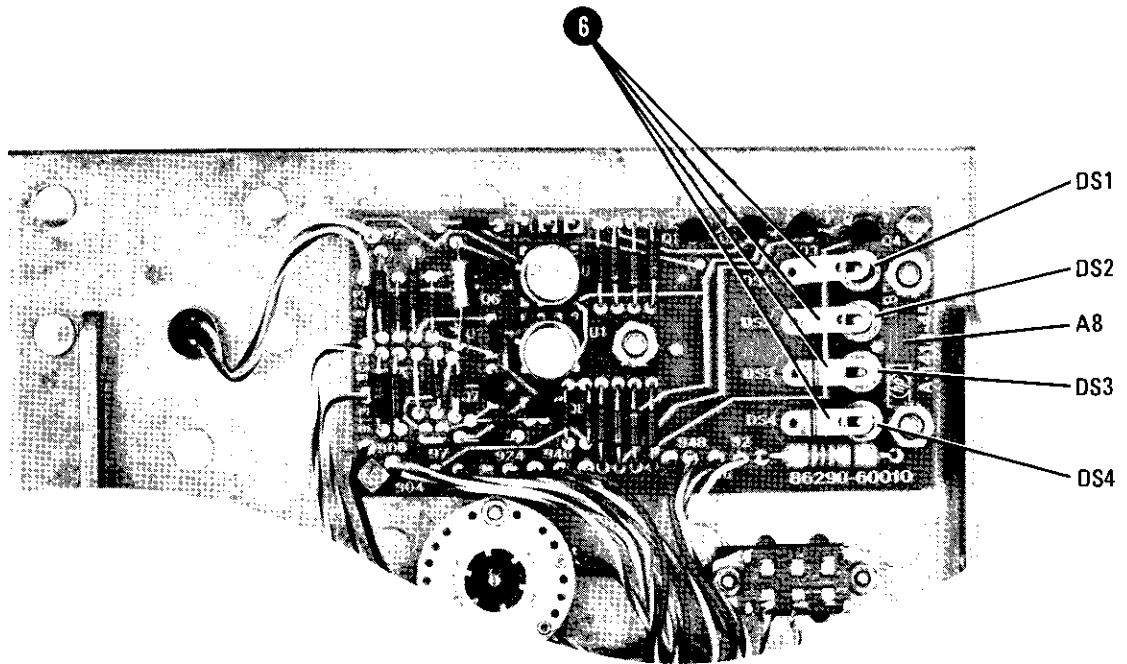

Figure 3-13. Band Indicator Lamp Replacement (2 of 2)

SECTION IV PERFORMANCE TESTS

4-1. INTRODUCTION

4-2. The procedures in this section test the electrical performance of the instrument using the specifications of Table 1-1 as the performance standards. All tests can be performed without access to the interior of the instrument. A simpler operational test is included in Section III under Operator's Checks.

4-3. The performance test procedures must be performed in the sequence given, since some procedures rely on satisfactory test results in foregoing steps. If a test measurement is slightly out of tolerance, go to Section V and perform adjustment procedures. If a function fails to operate, go to Section VIII and perform troubleshooting.

NOTE

In the following procedure, an 8620C mainframe is specified. However, an 8620A or 8620B may be used, but the control names will be different than

those called out in the procedures. These procedures assume that the mainframe is fully calibrated to its specifications.

4-4. EQUIPMENT REQUIRED

4-5. Equipment required for the performance tests is listed in the Recommended Test Equipment table in Section I. Any equipment that satisfies the critical specifications given in the table may be substituted for the recommended models.

4-6. TEST RECORD

4-7. Results of the performance tests may be recorded in the Test Record at the end of the procedures. The Test Record lists all of the tested specifications and their acceptable limits. Test results recorded at incoming inspection can be used for comparison in periodic maintenance and troubleshooting and after repairs or adjustments.

PERFORMANCE TESTS

4-8. FREQUENCY RANGE AND ACCURACY TEST

SPECIFICATION:

Table 4-1. Frequency Range and Accuracy Specifications

SPECIFICATION	BAND 1	BAND 2	BAND 3	BAND 4
Frequency Range:	2.0–6.2 GHz	6.0–12.4 GHz	12.0–18.0 GHz	2.0–18.0 GHz
Frequency Accuracy: (at 25° C)				
CW Mode (or Sweep Time > 0.1 sec with FM switch in PL or FM):	±20 MHz	±20 MHz	±20 MHz	±80 MHz
All sweep modes:	±30 MHz	±30 MHz	±30 MHz	±80 MHz
Marker	±30 MHz	±30 MHz	±30 MHz	±80 MHz

PERFORMANCE TESTS

4-8. FREQUENCY RANGE AND ACCURACY TEST (Cont'd)

RELATED ADJUSTMENT: Paragraph 5-16, YTO FREQUENCY RANGE ADJUSTMENTS

DESCRIPTION:

CW mode accuracy is checked at three frequencies across each band. Manual sweep accuracy is checked at endpoints of each band. Swept frequency endpoint accuracy is checked in each band using a calibrated frequency meter. Specifications are shown in Table 4-1.

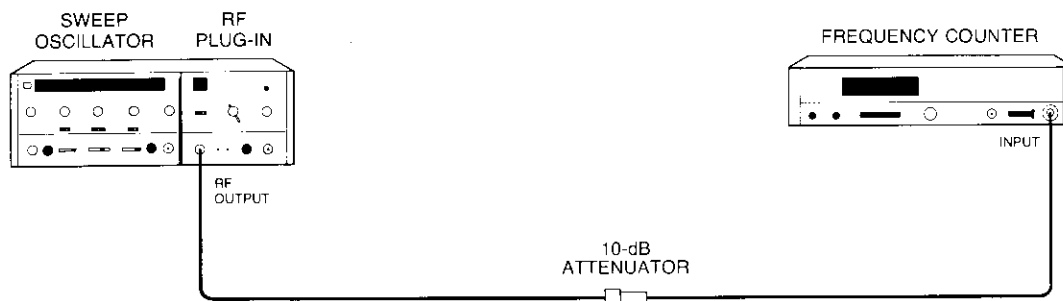

Figure 4-1. CW and Manual Sweep Accuracy Test Setup

NOTE

Equipment listed is for two test setups (Figures 4-1 and 4-2).

EQUIPMENT:

Sweep Oscillator	HP 8620C
RF Plug-in	HP 86290A
Frequency Counter	HP 5340A
Oscilloscope	HP 182C/1801A/1820C
Directional Coupler	HP 11691D, Option CO-1
Frequency Meter	HP 536A (0.96 — 4.2 GHz)
Frequency Meter	HP 537A (3.7 — 12.4 GHz)
Frequency Meter	HP P532A (12.4 — 18.0 GHz)
Coax-to-Waveguide Adapter	HP P281B (for use with HP P532A)
APC-7 to N Male Adapter	HP 11525A
Crystal Detector	HP 8470A
10-dB Attenuator	HP 8491B (Option 010)

PROCEDURE:

- a. Connect equipment as shown in Figure 4-1.

PERFORMANCE TESTS

4-8. FREQUENCY RANGE AND ACCURACY TEST (Cont'd)

b. Set controls as follows:

8620C:

BAND Band 1
 MODE MANUAL
 TRIGGER INT
 TIME-SECONDS1 — .01
 TIME-SECONDS Vernier Fully clockwise
 RF BLANKING/OFF (rear panel) RF BLANKING

86290A:

RF ON
 ALC INT
 POWER LEVEL Twelve O'clock
 FM-NORM-PL (rear panel) FM

c. Press 8620C LINE Pushbutton to ON and allow 30 minutes warm-up time.

CW Mode Accuracy

d. Press 8620C CW pushbutton; pushbutton should light. Set 8620C CW MARKER pointer to low-frequency end of scale. Frequency counter should indicate frequency shown in Table 4-2.

Table 4-2. CW Mode Accuracy at Low-Frequency Endpoints

BAND	CW MARKER POINTER	FREQUENCY COUNTER INDICATION
Band 1	2.0 GHz	2.000 GHz ±20 MHz
Band 2	6.0 GHz	6.000 GHz ±20 MHz
Band 3	12.0 GHz	12.000 GHz ±20 MHz
Band 4	2.0 GHz	2.000 GHz ±80 MHz

e. Set 8620C CW MARKER pointer to center-scale. Frequency counter should indicate frequency shown in Table 4-3.

Table 4-3. CW Mode Accuracy at Mid-Frequencies

BAND	CW MARKER POINTER	FREQUENCY COUNTER INDICATION
Band 1	4.1 GHz	4.100 GHz ±20 MHz
Band 2	9.2 GHz	9.200 GHz ±20 MHz
Band 3	15.0 GHz	15.000 GHz ±20 MHz
Band 4	10.0 GHz	10.000 GHz ±80 MHz

PERFORMANCE TESTS

4-8. FREQUENCY RANGE AND ACCURACY TEST (Cont'd)

- f. Set 8620C CW MARKER pointer to high-frequency end of scale. Frequency counter should indicate frequency shown in Table 4-4.

Table 4-4. CW Mode Accuracy at High-Frequency Endpoints

BAND	CW MARKER POINTER	FREQUENCY COUNTER INDICATION
Band 1	6.2 GHz	6.200 GHz \pm 20 MHz
Band 2	12.4 GHz	12.400 GHz \pm 20 MHz
Band 3	18.0 GHz	18.000 GHz \pm 20 MHz
Band 4	18.0 GHz	18.000 GHz \pm 80 MHz

Manual Sweep Accuracy

- g. Press 8620C MARKER SWEEP pushbutton. Set MANUAL control fully counterclockwise. Set START MARKER Pointer to low-frequency end of scale. Frequency counter should indicate frequency shown in Table 4-5.

Table 4-5. Manual Sweep Accuracy at Low-Frequency Endpoints

BAND	START MARKER POINTER	FREQUENCY COUNTER INDICATION
Band 1	2.0 GHz	2.000 GHz \pm 30 MHz
Band 2	6.0 GHz	6.000 GHz \pm 30 MHz
Band 3	12.0 GHz	12.000 GHz \pm 30 MHz
Band 4	2.0 GHz	2.000 GHz \pm 80 MHz

- h. Set MANUAL control fully clockwise. Set STOP MARKER pointer to high-frequency end of scale. Frequency counter should indicate frequency shown in Table 4-6.

Table 4-6. Manual Sweep Accuracy at High-Frequency Endpoints

BAND	STOP MARKER POINTER	FREQUENCY COUNTER INDICATION
Band 1	6.2 GHz	6.200 GHz \pm 30 MHz
Band 2	12.4 GHz	12.400 GHz \pm 30 MHz
Band 3	18.0 GHz	18.000 GHz \pm 30 MHz
Band 4	18.0 GHz	18.000 GHz \pm 80 MHz

PERFORMANCE TESTS

4-8. FREQUENCY RANGE AND ACCURACY TEST (Cont'd)

Swept Frequency Endpoint Accuracy

Figure 4-2. Swept Frequency Endpoint and Marker Accuracy Test Setup

- i. Connect equipment as shown in Figure 4-2; use appropriate frequency meter for frequency being checked.
- j. Set 8620C to Band 1. Press CW pushbutton. Adjust CW MARKER control for frequency counter indication of $2.000 \text{ GHz} \pm 2 \text{ MHz}$.
- k. Adjust frequency meter for minimum amplitude on oscilloscope. Note dial setting of frequency meter.
- l. Press 8620C FULL SWEEP pushbutton, set MODE switch to AUTO.
- m. Adjust frequency meter to low-frequency endpoint on oscilloscope. Determine the difference between end frequency and sweeper dial setting by subtracting this frequency meter setting from frequency meter setting noted in step k. This frequency difference must be less than 30 MHz.
- n. Repeat steps i through m for the bands and frequencies shown in Table 4-7.

PERFORMANCE TESTS

4-8. FREQUENCY RANGE AND ACCURACY TEST (Cont'd)

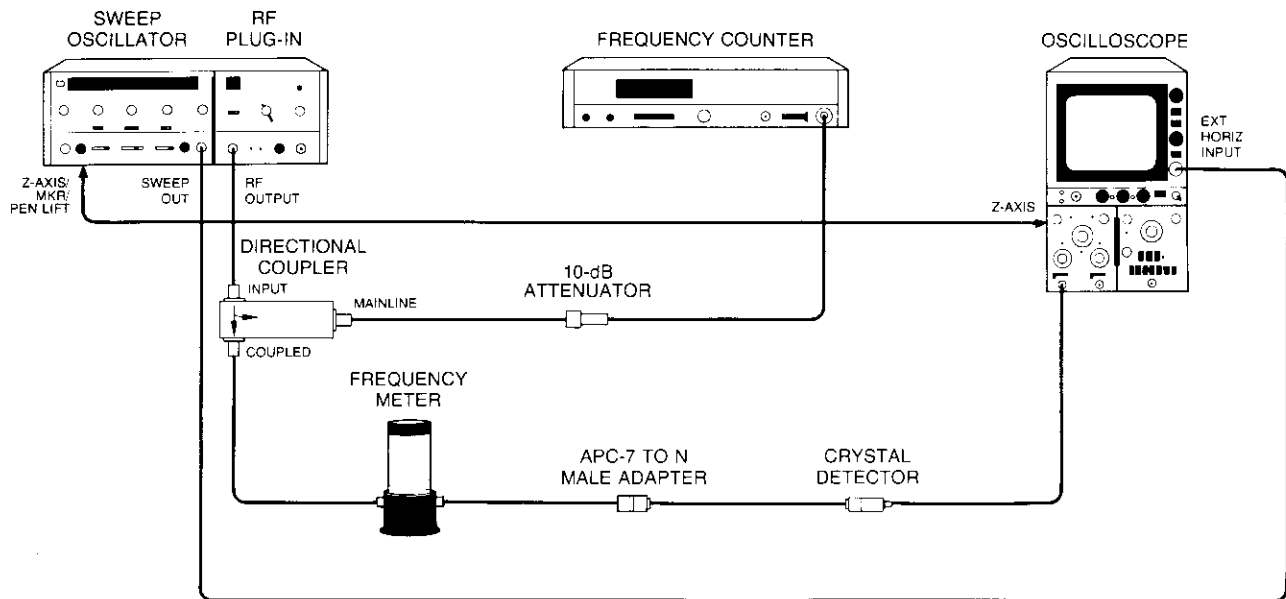
Table 4-7. Swept Frequency Endpoint Accuracy Test

BAND	FREQUENCY	FREQUENCY TOLERANCE
Band 1	6.2 GHz	±30 MHz
Band 2	6.0 GHz	±30 MHz
Band 2	12.4 GHz	±30 MHz
Band 3	12.0 GHz	±30 MHz
Band 3	18.0 GHz	±30 MHz
Band 4	2.0 GHz	±80 MHz
Band 4	18.0 GHz	±80 MHz

Marker Accuracy

- o. Set 8620C to Band 1. Press CW pushbutton. Adjust CW MARKER control for frequency counter indication of 4.100 GHz ±2 MHz.
- p. Adjust frequency meter for minimum amplitude on oscilloscope. Note dial setting of frequency meter.
- q. Set 8620C START MARKER Pointer to 3.0 GHz and STOP MARKER Pointer to 5.0 GHz. Press MARKER SWEEP pushbutton. Set CW MARKER pointer to 4.1 GHz. Set MARKER switch to INTEN.
- r. Adjust frequency meter to marker frequency on oscilloscope. Determine the difference between marker frequency and dial setting by subtracting this frequency from frequency meter setting in step p. Frequency difference must be less than 30 MHz.
- s. Repeat steps o through r for the bands and frequencies shown in Table 4-8.

Table 4-8. Marker Accuracy Test

BAND	CW MARKER POINTER (MARKER FREQUENCY)	START MARKER POINTER	STOP MARKER POINTER	FREQUENCY TOLERANCE
Band 2	9.2 GHz	8.0 GHz	10.0 GHz	±30 MHz
Band 3	15.0 GHz	14.0 GHz	16.0 GHz	±30 MHz
Band 4	10.0 GHz	9.0 GHz	11.0 GHz	±80 MHz

PERFORMANCE TESTS

4-9. FREQUENCY STABILITY TEST

SPECIFICATION:

Table 4-9. Frequency Stability Specifications

FREQUENCY STABILITY:	BAND 1	BAND 2	BAND 3	BAND 4
With 10% change in Line voltage:	±100 kHz	±100 kHz	±100 kHz	±100 kHz
With leveled 10-dB change in power:	±200 kHz	±400 kHz	±600 kHz	±600 kHz
With 3:1 load, SWR, all phases:	±100 kHz	±200 kHz	±300 kHz	±300 kHz
Residual FM (in 10 kHz bandwidth; FM-NORM-PL switch in NORM) CW Mode:	<±10 kHz	<±20 kHz	<±30 kHz	<±30 kHz

DESCRIPTION:

Frequency is measured for change due to line voltage, power, load, and residual FM.

PERFORMANCE TESTS

4-9. FREQUENCY STABILITY TEST (Cont'd)

Figure 4-3. Frequency Stability Test Setup

NOTE

Equipment listed is for three test setups (Figures 4-3, 4-4, and 4-5).

EQUIPMENT:

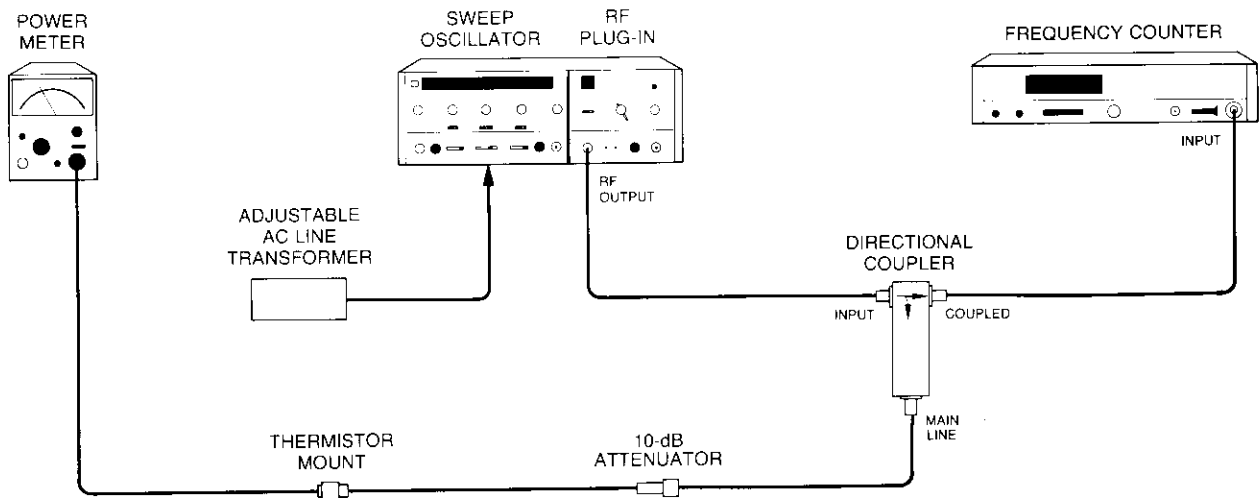
Sweep Oscillator	HP 8620C
RF Plug-in	HP 86290A
Frequency Counter	HP 5340A
Spectrum Analyzer	HP 8555A/8552B/141T
Power Meter	HP 432A
Thermistor Mount	HP 8478B
Directional Coupler	HP 11691D, Option CO-1
Adjustable AC Line Transformer	General Radio MT3A
3-dB Attenuator	HP 8491B, Option 003
10-dB Attenuator	HP 8491B, Option 010
Adjustable Short	Microlab FXR SO-6MN

PROCEDURE:*Frequency Change with Line Voltage Change*

- a. Connect equipment as shown in Figure 4-3 and set 8620C LINE switch to ON. Set adjustable line transformer to 115 Vac. Allow 30 minutes warm-up time.

PERFORMANCE TESTS

4-9. FREQUENCY STABILITY TEST (Cont'd)

b. Set controls as follows:

8620C:
 BAND Band 1
 TRIGGER INT

86290A:
 RF ON
 ALC INT

- c. Press 8620C CW pushbutton. Adjust 86290A POWER LEVEL control for maximum leveled power.
- d. Set 8620C CW MARKER pointer to 4.1 GHz. Note frequency indication on counter with line voltage at 115 Vac.
- e. Set line voltage to 103 Vac. Frequency change from that noted in step d should be less than ± 100 kHz.
- f. Set line voltage to 127 Vac. Frequency change from that noted in step d should be less than ± 100 kHz.
- g. Repeat steps d, e, and f for the bands and frequencies shown in Table 4-10.

Table 4-10. Frequency Change with Temperature

BAND	CW MARKER POINTER	FREQUENCY CHANGE
Band 2	9.2 GHz	< ± 100 kHz
Band 3	15.0 GHz	< ± 100 kHz
Band 4	10.0 GHz	< ± 100 kHz

Frequency Change with Power Level Change

- h. Set 8620C to Band 1 and CW MARKER pointer to 4.1 GHz. Set line voltage to 115 Vac. Adjust 86290A POWER LEVEL control for maximum leveled power. Note frequency indication on counter.
- i. Decrease 86290A power by 10 dB as indicated on power meter. Frequency change from that noted in step h should be less than ± 200 kHz.
- j. Repeat steps h and i for the bands and frequencies shown in Table 4-11.

PERFORMANCE TESTS

4-9. FREQUENCY STABILITY TEST (Cont'd)

Table 4-11. Frequency Change with Power Level

BAND	CW MARKER POINTER	FREQUENCY CHANGE
Band 2	9.2 GHz	<±400 kHz
Band 3	15.0 GHz	<±600 kHz
Band 4	10.0 GHz	<±600 kHz

Frequency Change with 3:1 Load SWR

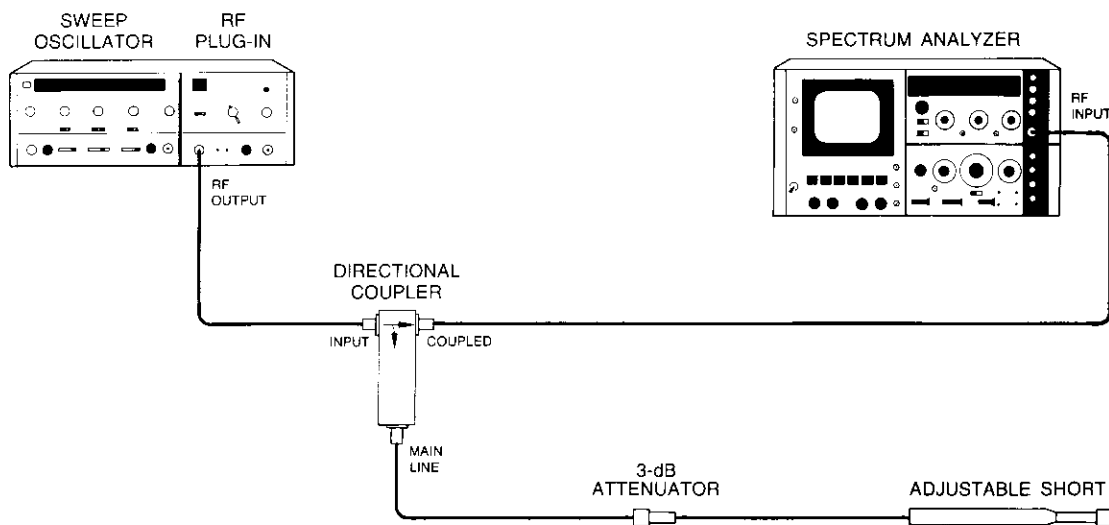

Figure 4-4. 3:1 Load SWR Test Setup

k. Connect equipment as shown in Figure 4-4. Allow 30 minutes warm-up time. Set controls as follows:

8620C:

BAND Band 1
 CW MARKER Pointer 4.1 GHz

86290A:

RF ON
 ALC INT
 FM-NORM-PL NORM

- l. Press 8620C CW pushbutton. Adjust 86290A for maximum leveled power. Center output signal on spectrum analyzer display.
- m. Set spectrum analyzer bandwidth to 10 kHz and scan width to 50 kHz/division while keeping the signal centered on display.

PERFORMANCE TESTS

4-9. FREQUENCY STABILITY TEST (Cont'd)

- n. Set spectrum analyzer to 10-dB/division sensitivity and adjust for full vertical display.
- o. Set scan time to 20 msec/division, internal scan mode and automatic scan trigger.
- p. Adjust the adjustable short through its range while observing the frequency change on analyzer. Frequency change must be less than ± 100 kHz.
- q. Repeat steps 1 through p for the bands and frequencies shown in Table 4-12.

Table 4-12. Frequency Change with 3:1 Load SWR

BAND	CW MARKER POINTER	FREQUENCY CHANGE
Band 2	9.2 GHz	$< \pm 200$ kHz
Band 3	15.0 GHz	$< \pm 300$ kHz
Band 4	10.0 GHz	$< \pm 300$ kHz

Residual FM

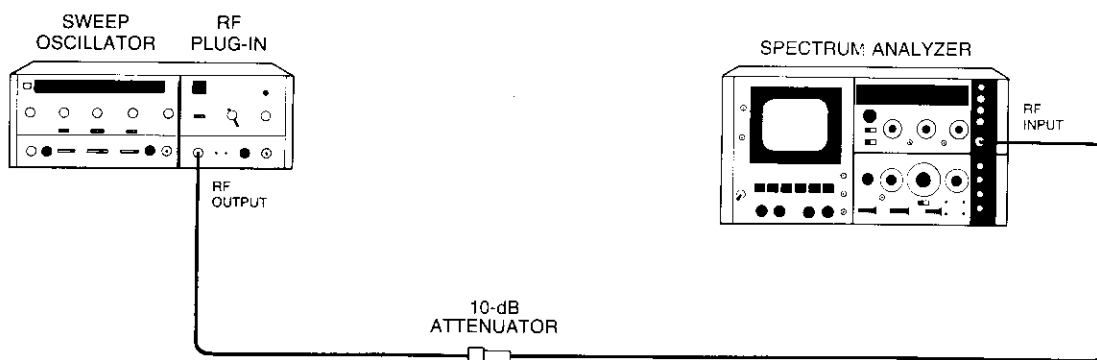

Figure 4-5. Residual FM Test Setup

- r. Connect equipment as shown in Figure 4-5. Allow 30 minutes warm-up time. Set controls as follows:

8620C:

BAND Band 1
 CW MARKER Pointer 4.1 GHz

86290A:

RF ON
 ALC INT
 FM-NORM-PL (rear panel) NORM

PERFORMANCE TESTS

4-9. FREQUENCY STABILITY TEST (Cont'd)

- s. Press 8620C CW pushbutton. Center RF output signal on spectrum analyzer display.
- t. Set spectrum analyzer bandwidth to 10 kHz and scan width to 10 kHz/division while keeping signal centered on display. Set analyzer to 10-dB/division sensitivity and adjust for full vertical display.
- u. Set scan time to 20 msec/division and scan mode to internal.
- v. Spectrum analyzer display should be similar to Figure 4-6. Frequency deviation measured across top of trace should be less than 10 kHz peak (20 kHz peak-to-peak).
- w. Repeat steps s through v for the bands and frequencies shown in Table 4-13.

Table 4-13. Residual FM Frequency Deviation

BAND	CW MARKER POINTER	MAXIMUM DEVIATION
Band 2	9.2 GHz	20 kHz peak
Band 3	15.0 GHz	30 kHz peak
Band 4	10.0 GHz	30 kHz peak

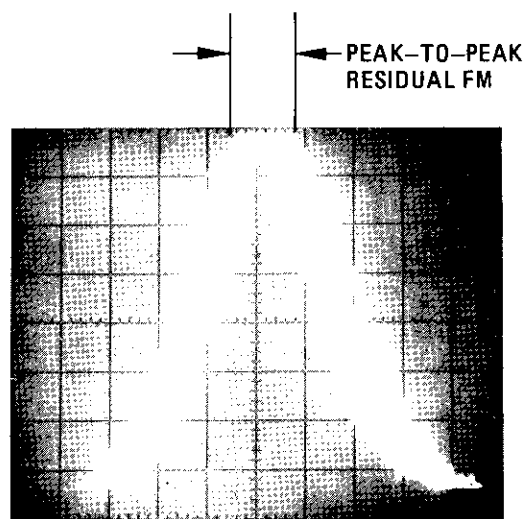

Figure 4-6. Residual FM Displayed on Spectrum Analyzer

PERFORMANCE TESTS

4-10. POWER LEVEL AND VARIATION TEST

SPECIFICATION:

Table 4-14. Power Level and Power Variation Specifications

SPECIFICATION	BAND 1	BAND 2	BAND 3	BAND 4
Maximum Leveled Power (25°C):	>+5 dBm	>+5 dBm	>+5 dBm	>+5 dBm
Power Variations (at maximum leveled power):				
Internally Leveled	<±0.7 dB	<±0.7 dB	<±0.8 dB	<±0.9 dB
Crystal Detector Leveled (External) ¹	<±0.15 dB	<±0.15 dB	<±0.15 dB	<±0.15 dB
Power Meter Leveled (External) ²	<±0.15 dB	<±0.15 dB	<±0.15 dB	<±0.15 dB
¹ Excluding coupler and detector variations. ² Use HP Model 432A Power Meter: sweep duration >10 seconds.				

RELATED ADJUSTMENT:

Paragraphs 5-17, YTM SLOW SPEED TRACKING ADJUSTMENTS and Paragraph 5-20 or 5-21, ALC ADJUSTMENTS.

DESCRIPTION:

Maximum leveled power is measured with a power meter. Power level variations with internal leveling, crystal detector leveling, and power meter leveling are checked. In each mode, the power variations are measured on the oscilloscope. The trace is calibrated by changing the RF output power by the amount of the specification as noted on the power meter and the corresponding change in the oscilloscope trace position.

In the internal leveling test, the oscilloscope is calibrated with the power meter, then the oscillator output is routed through a 10-dB attenuator and crystal detector to the oscilloscope vertical input. Removing the thermistor mount and directional coupler from the test setup eliminates errors due to frequency response variations in these devices. In the external leveling modes, the frequency response variations do not affect the oscilloscope display because the leveling variations are monitored in the feedback loop. However, the usable RF power output from the directional coupler will have level variations as a result of the frequency response characteristics of the thermistor mount, crystal detector, and directional coupler.

PERFORMANCE TESTS

4-10. POWER LEVEL AND VARIATION TEST (Cont'd)

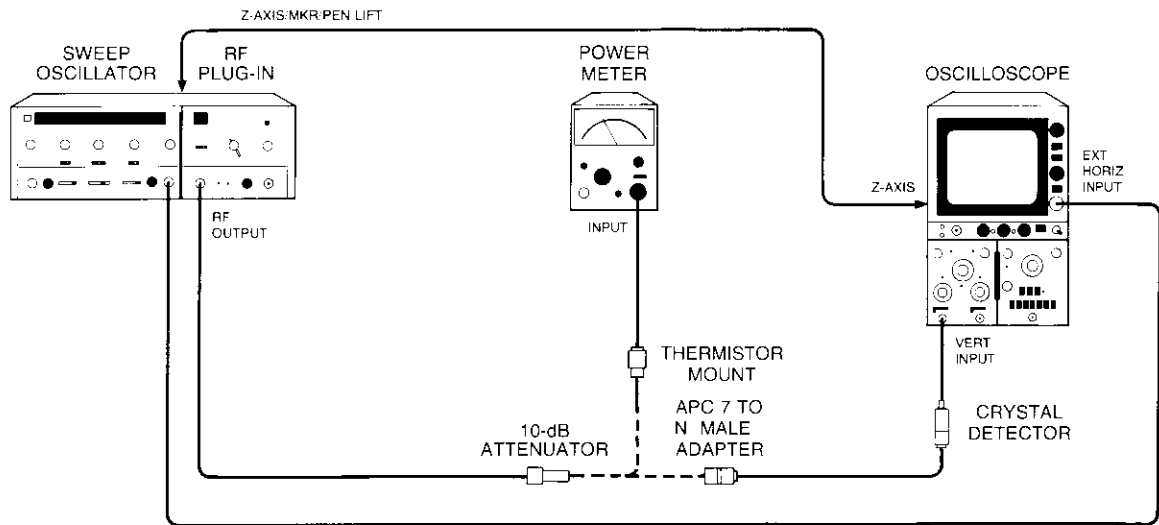

Figure 4-7. Internal Leveling Test Setup

NOTE

Equipment listed is for three test setups (Figures 4-7, 4-8 and 4-9)

EQUIPMENT:

Sweep Oscillator	HP 8620C
RF Plug-in	HP 86290A
Oscilloscope	HP 182C/1801A/1820C
Power Meter	HP 432A
Thermistor Mount	HP 8478B
Directional Couplers	HP 11691D, Option CO-1
Crystal Detector	HP 8470A
10-dB Attenuator	HP 8491B, Option 010
APC-7 to N Male Adapter	HP 11525A

PROCEDURE:

- a. Connect equipment as shown in Figure 4-7 with RF OUTPUT connected to crystal detector and oscilloscope. Allow 30 minutes warm-up time. Set controls as follows:

8620C:

BAND	Band 4
MODE	AUTO
TRIGGER	INT
TIME-SECONDS1 — .01
TIME-SECONDS Vernier	Fully clockwise
RF BLANKING/OFF (rear panel)	RF BLANKING
DISPLAY BLANKING/OFF (rear panel)	DISPLAY BLANKING

PERFORMANCE TESTS

4-10. POWER LEVEL AND VARIATION TEST (Cont'd)

86290A:

RF ON
 ALC INT
 FM-NORM-PL (rear panel) FM

- b. Adjust 86290A POWER LEVEL, PEAK, and SLOPE controls for maximum leveled power as indicated on oscilloscope.

Internal Leveling

- c. Connect equipment as shown in Figure 4-7 with RF OUTPUT connected to thermistor mount and power meter.
- d. Press 8620C CW pushbutton. Slowly rotate CW MARKER control through entire range while observing power meter reading. Minimum power should be greater than +5 dBm. Note minimum power point reading.
- e. Adjust CW MARKER control to minimum power point as observed on power meter. Set 86290A POWER LEVEL control fully counterclockwise and note power meter indication. This reading should be at least 10 dB below minimum power point reading in step d. Adjust power to +5.0 dBm ±0.1 dB.
- f. Connect equipment as shown in Figure 4-7 with RF OUTPUT connected to crystal detector and oscilloscope. Adjust oscilloscope to establish +5 dBm reference on top horizontal graticule.
- g. Connect equipment as shown in Figure 4-7 with RF OUTPUT connected to thermistor mount and power meter. Adjust 86290A power to +6.4 dBm ±0.1 dB. (It may be necessary to change frequency.)
- h. Connect equipment as shown in Figure 4-7 with RF OUTPUT connected to crystal detector and oscilloscope. Note +6.4 dBm reference point on oscilloscope; area between this trace position and top graticule line represents leveling tolerance of ±0.7 dB.
- i. Set 8620C to Band 1 and press FULL SWEEP pushbutton. Adjust 86290A for maximum leveled power. Trace on oscilloscope should be below top horizontal graticule (+5 dBm power reference).
- j. Adjust oscilloscope vertical position control to set upper point of trace (minimum power point) on top horizontal graticule. Lower point of trace (maximum power point) should be above reference point established in step h.
- k. Repeat steps g through j for each band listed in Table 4-15, using the reference power listed to establish leveling tolerance in step g.

Table 4-15. Internal Leveling Power Level and Variation

BAND	REFERENCE POWER
Band 2	+6.4 dBm
Band 3	+6.6 dBm
Band 4	+6.8 dBm

PERFORMANCE TESTS

4-10. POWER LEVEL AND VARIATION TEST (Cont'd)

Crystal Detector Leveling

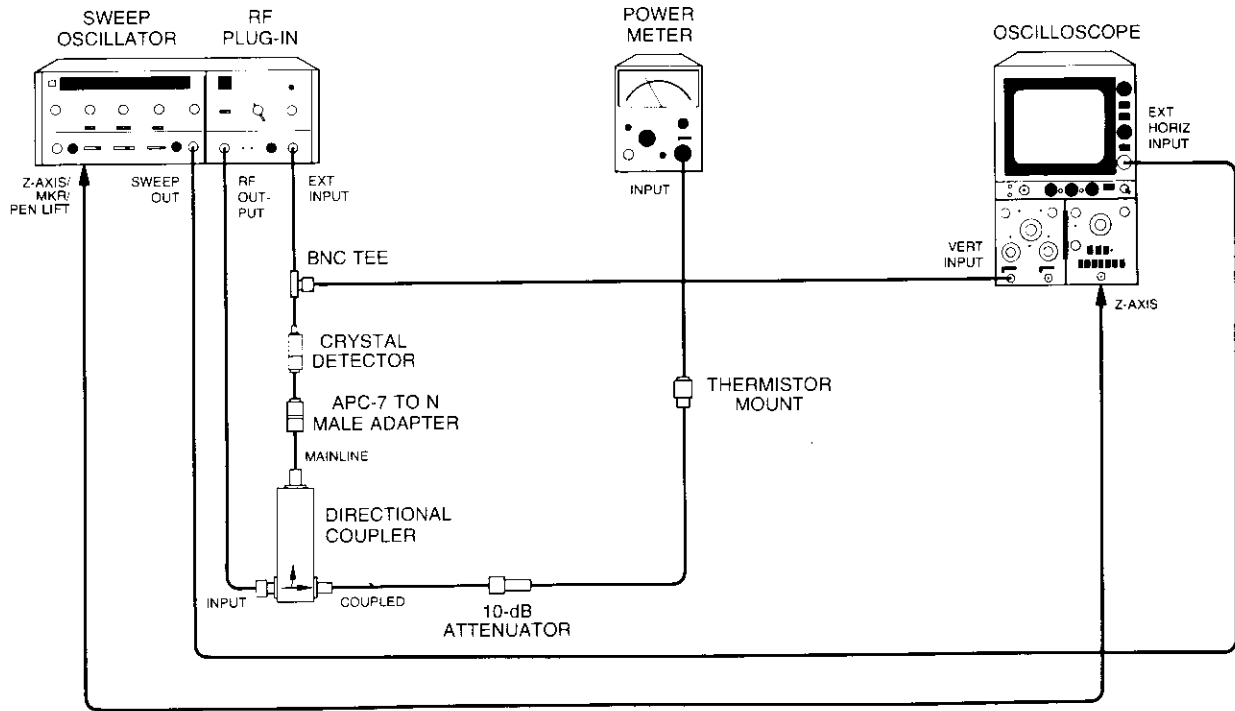

Figure 4-8. Crystal Detector Leveling Test Setup

- l. Connect equipment as shown in Figure 4-8. Allow 30 minutes warm-up time.

NOTE

The HP 8470A Crystal Detector has a negative output.

- m. Set controls as follows:

8620C:

BAND	Band 4
CW MARKER Pointer	10.0 GHz
MODE	AUTO
TRIGGER	INT
TIME-SECONDS1 — .01
TIME-SECONDS Vernier	Fully clockwise
RF BLANKING/OFF (rear panel)	RF BLANKING
DISPLAY BLANKING/OFF (rear panel)	DISPLAY BLANKING

86290A:

RF	ON
ALC	EXT

PERFORMANCE TESTS

4-10. POWER LEVEL AND VARIATION TEST (Cont'd)

- n. Press 8620C FULL SWEEP pushbutton. Adjust 86290A POWER LEVEL, PEAK, and ALC GAIN controls to obtain maximum leveled power as indicated on oscilloscope.
- o. Press 8620C CW pushbutton. Adjust oscilloscope trace to center graticule line. Decrease output power indication at power meter by 0.3 dB by adjusting 86290A POWER LEVEL control. Note new position of oscilloscope trace; area between this trace position and center graticule line represents leveling tolerance of ± 0.15 dB.
- p. Press 8620C FULL SWEEP pushbutton.
- q. Adjust position of oscilloscope trace vertically so lowest point of trace is on center horizontal graticule. The highest point of the trace should be within the leveled variation limits established in step o.

Power Meter Leveling

Figure 4-9. Power Meter Leveling Test Setup

- r. Connect equipment as shown in Figure 4-9. Allow 30 minutes warm-up time.

NOTE

The HP 432A Power Meter has a positive output.

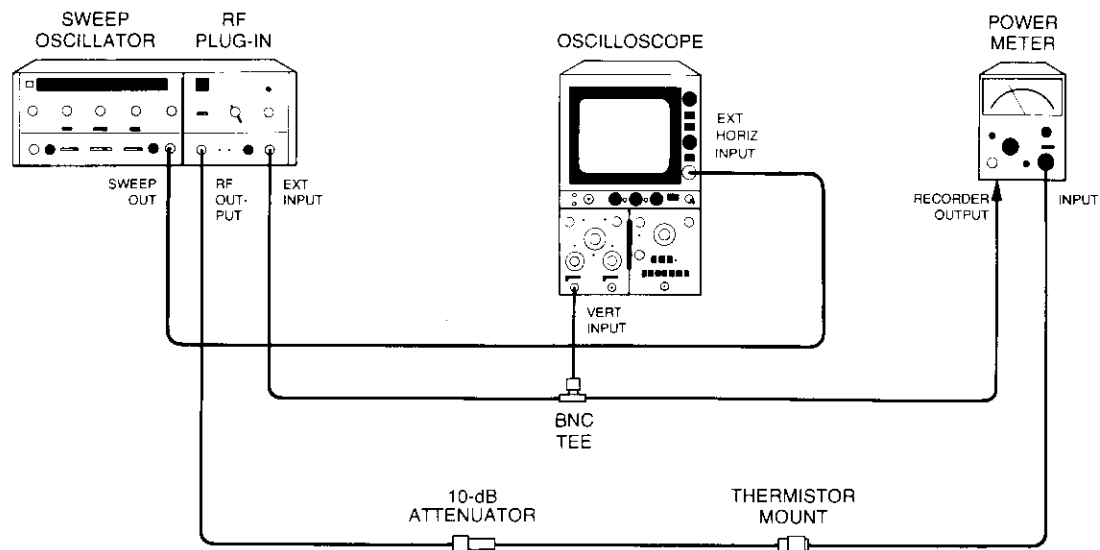
PERFORMANCE TESTS

4-10. POWER LEVEL AND VARIATION TEST (Cont'd)

s. Set controls as follows:

8620C:

BAND	Band 4
MODE	AUTO
TRIGGER	INT
TIME-SECONDS	100 to 10
TIME-SECONDS Vernier	Fully clockwise
RF BLANKING/OFF (rear panel)	RF BLANKING
DISPLAY BLANKING/OFF (rear panel)	DISPLAY BLANKING

86290A:

RF	ON
ALC	MTR
ALC GAIN	Fully clockwise

NOTE

For power meter leveling, sweep rates slower than 10 sec/sweep should be used to ensure proper leveling due to the slow response time of the thermistor mount.

- t. Press 8620C FULL SWEEP pushbutton. Set power meter range as necessary to maintain power meter indication in upper half of scale. Adjust 86290A POWER LEVEL and PEAK controls to obtain maximum leveled power as observed on oscilloscope.
- u. Set 8620C MODE switch to MANUAL. Slowly rotate MANUAL control through full range. Note minimum power point on power meter. Adjust oscilloscope trace dot to minimum power point with 8620C MANUAL control. Adjust 86290A POWER LEVEL control to set minimum power point to +5 dBm as indicated on power meter.
- v. Set 8620C MODE switch to AUTO. Observe minimum and maximum power meter readings. Total variation should not exceed 0.3 dB.

4-11. RESIDUAL AM TEST**SPECIFICATION:**

AM noise in a 100 kHz bandwidth (below fundamental at specified maximum power): > 55 dB.

DESCRIPTION:

The carrier signal from the 86290A Plug-in is amplitude modulated with a squarewave from the 8620C Sweep Oscillator. The modulated signal is used to establish a reference on the RMS Voltmeter that is 9 dB below the actual carrier signal. The 9-dB reduction occurs because of the voltmeter response to a squarewave and the square-law response of the crystal detector. The modulation is removed and the magnitude of the Residual AM component is measured with respect to the established reference.

PERFORMANCE TESTS

4-11. RESIDUAL AM TEST (Cont'd)

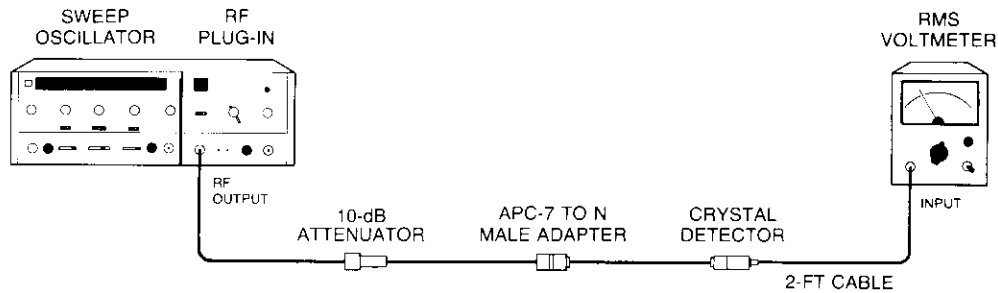

Figure 4-10. Residual AM Test Setup

EQUIPMENT:

Sweep Oscillator	HP 8620C
RF Plug-in	HP 86290A
RMS Voltmeter	HP 3400A
10-dB Attenuator	HP 8491B, Option 010
Crystal Detector	HP 8470A
2-foot BNC to BNC Cable	HP 11086A
APC-7 to N Male Adapter	HP 11525A

PROCEDURE:

- a. Connect equipment as shown in Figure 4-10. Allow 30 minutes warm-up time. Set controls as follows:

8620C:

BAND	Band 4
CW MARKER Pointer	10.0 GHz
1 kHz SQ WV/OFF (rear panel)	1 kHz SQ WV
RF BLANKING/OFF (rear panel)	RF BLANKING

86290A:

RF	ON
ALC	INT

- b. Adjust 86290A for maximum leveled power. Press CW pushbutton.

NOTE

Any CW frequency between 2.0 GHz and 18.0 GHz may be used for this test.

- c. Set RMS voltmeter to a range that gives an on-scale indication. Note meter indication.

PERFORMANCE TESTS

4-11. RESIDUAL AM TEST (Cont'd)

- d. Set 8620C rear-panel 1 kHz SQ W V/OFF switch to OFF. Set RMS voltmeter to a range that gives an on-scale reading. The difference between this reading and the reading in step c should be a minimum of 46 dB.

NOTE

A 46-dB decrease in the RMS voltmeter indication corresponds to a 55-dB reduction in signal level. A correction factor of 9 dB is added because of the RMS voltmeter response to a squarewave and the square-law response of the crystal detector.

4-12. SPURIOUS SIGNALS TEST

SPECIFICATION:

Test is measured in dB below fundamental at specified maximum power, 2.0 — 18.0 GHz.

Harmonically Related Signals	> 25 dB
Nonharmonics	> 50 dB

DESCRIPTION:

The RF signal is displayed on a spectrum analyzer to verify spurious signal output is down from the fundamental frequency by the specified amount.

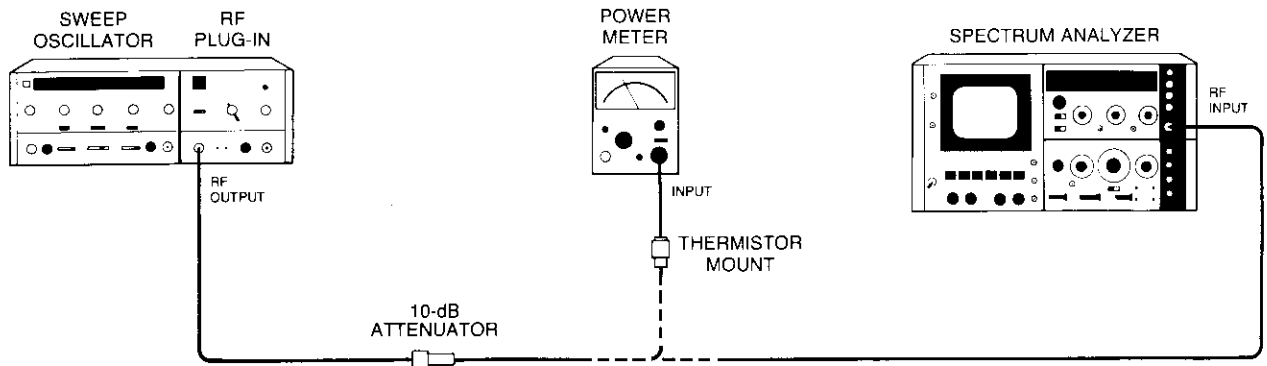

Figure 4-11. Spurious Signal Test Setup

EQUIPMENT:

Sweep Oscillator	HP 8620C
RF Plug-in	HP 86290A
Spectrum Analyzer	HP 8555A/8552B/141T
Power Meter	HP 432A
Thermistor Mount	HP 8478B
10-dB Attenuator	HP 8491B, Option 010

PERFORMANCE TESTS

4-12. SPURIOUS SIGNALS TEST (Cont'd)

PROCEDURE:

a. Connect equipment as shown in Figure 4-11 with power meter connected through a 10-dB attenuator to 86290A RF OUTPUT connector. Allow 30 minutes warm-up time.

b. Set controls as follows:

8620C:

BAND Band 4
MODE MANUAL

86290A:

RF ON
ALC INT
FM-NORM-PL (rear panel) NORM

c. Adjust 86290A for leveled power with minimum power point set to +5 dBm.

d. Connect spectrum analyzer input through 10-dB attenuator to 86290A RF OUTPUT connector. Adjust spectrum analyzer reference level to place fundamental signal on top horizontal graticule.

e. Rotate MANUAL control through its entire range while observing spectrum analyzer display from 2.0 GHz to 18.0 GHz. All harmonically-related signals should be greater than 25 dB down from fundamental and all non-harmonic-related signals should be down greater than 50 dB.

NOTE

The spectrum analyzer may originate some mixing products that may appear on the display. If a signal is in question, increase the spectrum analyzer input attenuation by 10 dB, then return the attenuator to the original position. If the signal in question originates in the spectrum analyzer, the level will change by some amount other than 10 dB.

4-13. EQUIVALENT SOURCE SWR TEST

SPECIFICATION:

SWR: < 1.9 (for all bands, internally leveled, 50-ohm nominal impedance)

DESCRIPTION:

The wideband (2.0 to 18.0 GHz) 86290A RF output signal is measured using a directional coupler, crystal detector, and oscilloscope. The signal from the plug-in contains (1) the initial signal from the oscillator, and (2) the reflected signal. The reflected signal is developed as follows: The original oscillator signal travels down the 20-cm airlines, sees the open, and is reflected back to the source. If the reflected signal going into the RF OUTPUT connector sees a perfect 50-ohm source match, no signal is reflected back out of the source. However, the greater the mismatch, the greater the reflected signal. The reflected signal adds and subtracts in and out of phase with the original oscillator signal and is displayed on the oscilloscope.

PERFORMANCE TESTS

4-13. EQUIVALENT SOURCE SWR TEST (Cont'd)

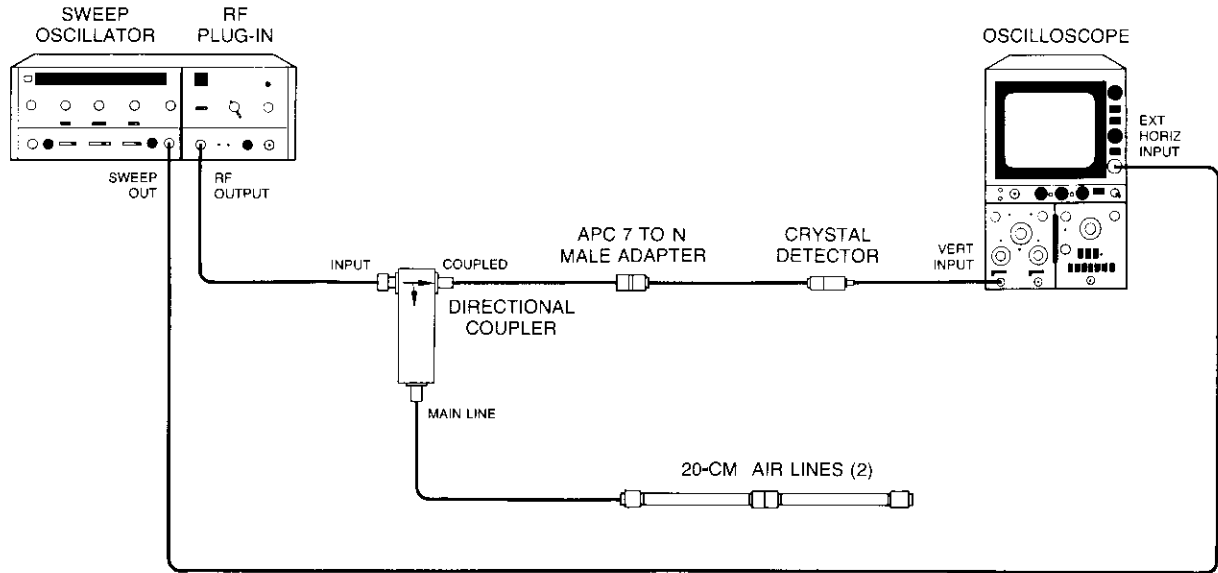

Figure 4-12. Equivalent Source Match SWR Test Setup

EQUIPMENT:

Sweep Oscillator	HP 8620C
RF Plug-in	HP 86290A
Oscilloscope	HP 182C/1801A/1820C
Crystal Detector	HP 8470A
Directional Coupler	HP 11691D, Option CO-1
20-cm Air Lines (2 required)	HP 11567A
APC-7 to N Male Adapter	HP 11525A

PERFORMANCE TESTS

4-13. EQUIVALENT SOURCE SWR TEST (Cont'd)

PROCEDURE:

- a. Connect equipment as shown in Figure 4-12. Allow 30 minutes warm-up time. Set controls as follows:

8620C:

BAND Band 4
 TIME-SECONDS1 — .01
 TIME-SECONDS Vernier Fully clockwise
 DISPLAY BLANKING/OFF (rear panel) DISPLAY BLANKING

86290A:

RF ON
 ALC INT

- b. Press 8620C FULL SWEEP pushbutton. Adjust 86290A for leveled power and <25 mV maximum deflection as observed on oscilloscope to ensure square-law output of crystal detector.
- c. Display swept power output trace on oscilloscope (Figure 4-13). Select largest V_{MAX}/V_{MIN} ratio on oscilloscope display and convert it to source SWR, using Figure 4-14. The SWR should be <1.9.

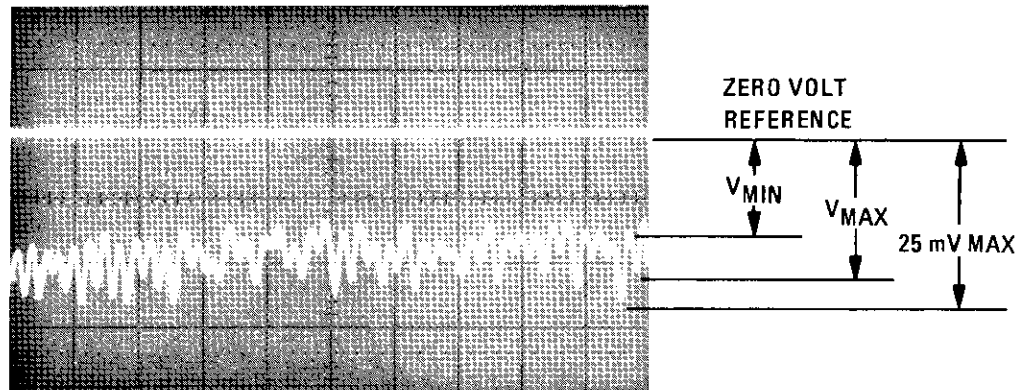

Figure 4-13. Typical Pattern of a Swept SWR Measurement

PERFORMANCE TESTS

4-13. EQUIVALENT SOURCE SWR TEST (Cont'd)

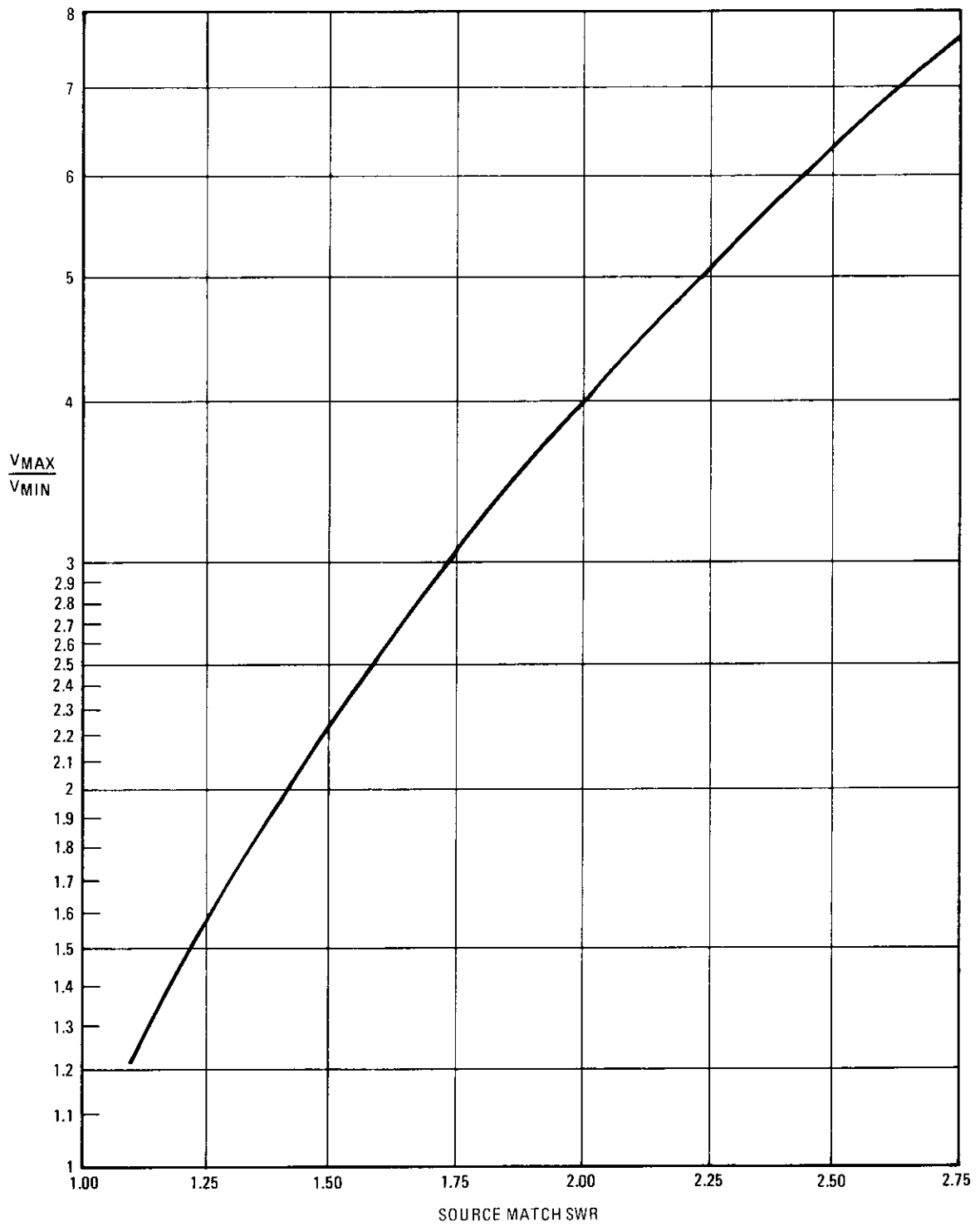

Figure 4-14. Graph for Converting Oscilloscope Trace to Source Match SWR

PERFORMANCE TESTS

4-14. EXTERNAL FREQUENCY MODULATION TEST

SPECIFICATION:

(86290A FM-NORM-PL Switch in FM position)

Modulation Frequencies	Maximum Deviation
DC to 100 Hz	± 75 MHz
100 Hz to 2 MHz	± 5 MHz

RELATED ADJUSTMENT:

Paragraph 5-13, FREQUENCY MODULATION BALANCE ADJUSTMENT.

DESCRIPTION:

The 86290A is modulated by an external signal source at 10 Hz, 100 Hz, 900 kHz, and 2.1 MHz. Deviation from low modulation frequencies (10 Hz and 100 Hz) is measured directly by the spectrum analyzer. Deviation from high modulation frequencies (900 kHz and 2.1 MHz) is measured on the spectrum analyzer using the carrier-null method.

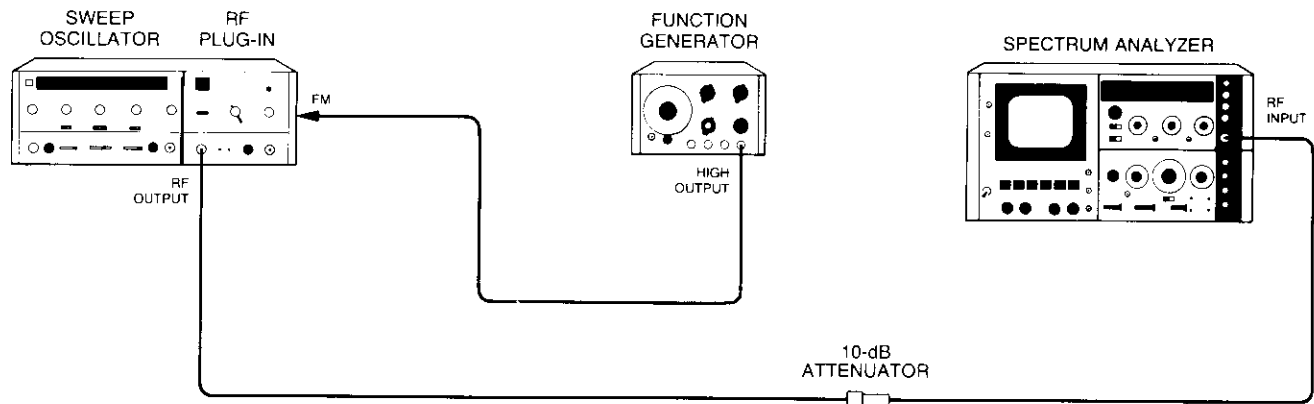

Figure 4-15. External Frequency Modulation Test Setup

EQUIPMENT:

Sweep Oscillator	HP 8620C
RF Plug-in	HP 86290A
Function Generator	HP 3310A
Spectrum Analyzer	HP 8555A/8552B/141T
10-dB Attenuator	HP 8491B, Option 010

PROCEDURE:

- a. Connect equipment as shown in Figure 4-15. Set 8620C LINE switch ON and allow 30 minutes warm-up time.

PERFORMANCE TESTS

4-14. EXTERNAL FREQUENCY MODULATION TEST (Cont'd)

b. Set controls as follows:

8620C:

BAND Band 1
 CW MARKER Pointer 4.1 GHz
 RF BLANKING/OFF (rear panel) RF BLANKING

86290A:

RF ON
 ALC INT
 FM-NORM-PL (rear panel) FM

- c. Press 8620C CW pushbutton. Adjust 86290A for maximum leveled power. Set function generator frequency to 10 Hz and amplitude to minimum.
- d. Set spectrum analyzer bandwidth to 300 kHz, scan width to 50 MHz/division, scan time per division to 1.0 msec, and sensitivity to 10 dB/division.

Low Frequency FM

- e. Adjust spectrum analyzer to center RF carrier on display. Increase function generator amplitude while observing spectrum analyzer display.

NOTE

As modulation amplitude is increased, the trace will have linear deviation as shown in Figure 4-16. Excessive modulation amplitude will cause non-linear deviation as shown in Figure 4-17.

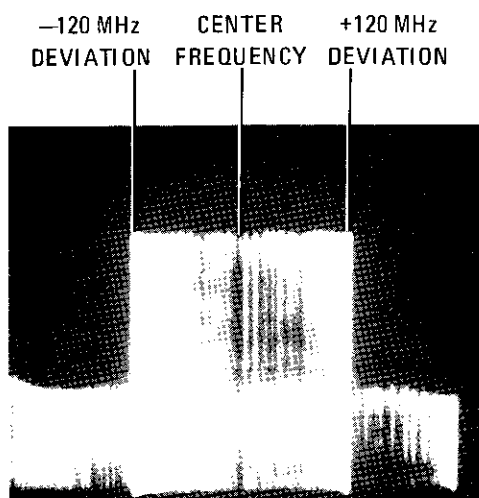

Figure 4-16. Spectrum Analyzer Display of Linear Frequency Modulation

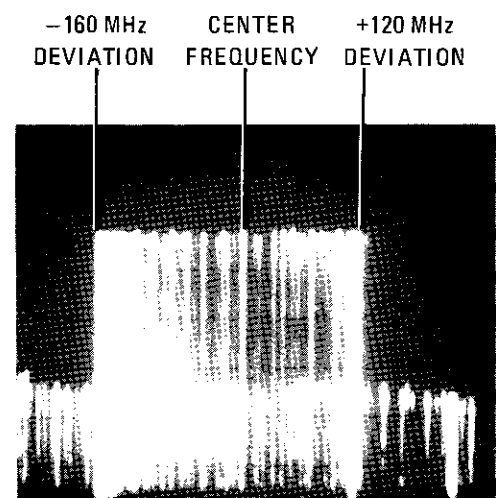

Figure 4-17. Spectrum Analyzer Display of Non-linear Frequency Modulation

PERFORMANCE TESTS

4-14. EXTERNAL FREQUENCY MODULATION TEST (Cont'd)

- f. Adjust function generator amplitude to produce maximum linear deviation as shown on spectrum analyzer. Deviation should be greater than ± 75 MHz.
- g. Set function generator frequency to 100 Hz. Adjust function generator amplitude to produce maximum linear deviation. Deviation should be greater than ± 75 MHz.
- h. Repeat steps c through g for the bands and frequencies shown in Table 4-16.

High Frequency FM

- i. Set controls as follows:
 8620C:
 BAND Band 1
 C V MARKER Pointer 4.1 GHz
- j. Adjust 86290A for maximum leveled power. Set function generator frequency to 900 kHz and amplitude to minimum.
- k. Set spectrum analyzer bandwidth to 30 kHz and scan width to 2 MHz/division.
- l. Adjust spectrum analyzer to center RF carrier on display. Increase function generator amplitude while observing spectrum analyzer display. Sidebands will appear and carrier amplitude will start to decrease. Increase function generator amplitude through first carrier null and up to second carrier null as shown in Figure 4-18. This point is ± 5 MHz deviation.
- m. Set function generator frequency to 2.1 MHz and amplitude to minimum. Increase function generator amplitude to produce first carrier null as shown in Figure 4-19. This point is ± 5 MHz deviation.
- n. Repeat steps j through m for the bands and frequencies shown in Table 4-17.

Table 4-16. Low Frequency FM

BAND	CW FREQUENCY
Band 2	9.2 GHz
Band 3	15.0 GHz
Band 4	10.0 GHz

Table 4-17. High Frequency FM

BAND	CW FREQUENCY
Band 2	9.2 GHz
Band 3	15.0 GHz
Band 4	10.0 GHz

PERFORMANCE TESTS

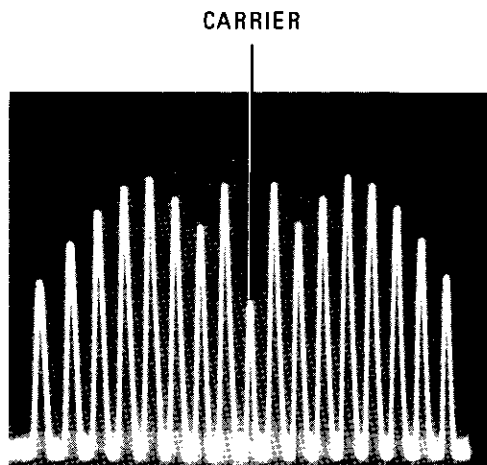
4-14. EXTERNAL FREQUENCY MODULATION TEST (Cont'd)

*Figure 4-18. Spectrum Analyzer
Display of Second Carrier-null
with 900 kHz Modulation
Frequency*

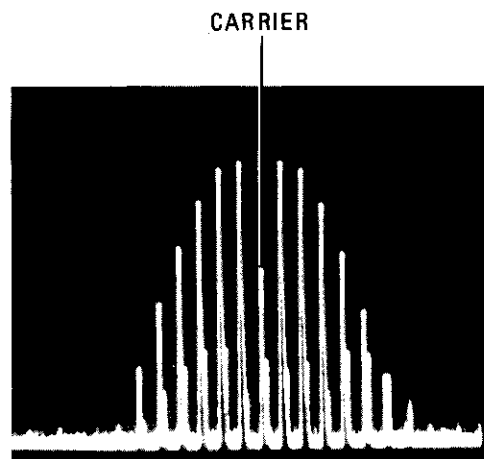

*Figure 4-19. Spectrum Analyzer
Display of First Carrier-null
with 2.1 MHz Modulation
Frequency*

4-15. AMPLITUDE MODULATION TEST**SPECIFICATION:**

All tests are referenced to the 86290A RF OUTPUT power set to the specified maximum power of +5 dBm.

Internal AM:

- RF Blanking (Selected by RF BLANKING/OFF switch) ON/OFF ratio > 30 dB
- 1 kHz Square Wave (Selected by 1 kHz SQ WV/OFF switch) ON/OFF ratio > 25 dB

External AM:

- 27.8 kHz, $\pm 6V$ Square Wave ON/OFF ratio > 30 dB
- Symmetry 45/55
- Attenuation for +5 Vdc Input > 30 dB

RELATED ADJUSTMENT:

Paragraph 5-20 or 5-21, ALC ADJUSTMENTS.

DESCRIPTION:

Internal AM is checked for RF blanking and 1 kHz square wave modulation on/off ratios. The on/off ratio is determined by power level measurement in the ON and OFF conditions. External AM is checked with 27.8 kHz, $\pm 6V$ square wave to ensure compatibility with the HP 8755A Swept Amplitude Analyzer. Sensitivity is checked by applying +5 Vdc and checking the resulting attenuation.

PERFORMANCE TESTS

4-15. AMPLITUDE MODULATION TEST (Cont'd)

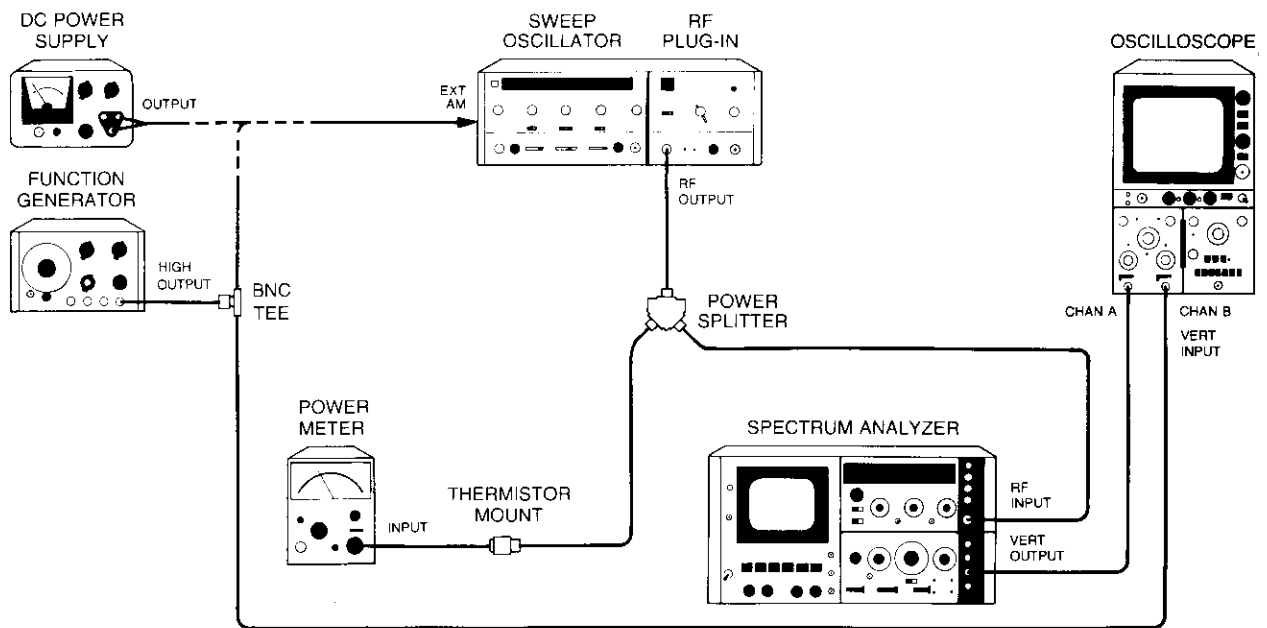

Figure 4-20. Amplitude Modulation Test Setup

EQUIPMENT:

Sweep Oscillator	HP 8620C
RF Plug-in	HP 86290A
DC Power Supply	HP 721A
Power Meter	HP 432A
Thermistor Mount	HP 8478B
Spectrum Analyzer	HP 8555A/8552B/141T
Oscilloscope	HP 182C/1801A/1820C
Power Splitter	HP 11667A
BNC Tee	HP 1250-0781
Function Generator	HP 3310A

PERFORMANCE TESTS

4-15. AMPLITUDE MODULATION TEST (Cont'd)

PROCEDURE:

- a. Connect equipment as shown in Figure 4-20 with DC Power Supply connected to EXT AM. Allow 30 minutes warm-up time.
- b. Set controls as follows:

8620C:

BAND	Band 4
CW MARKER Pointer	10.0 GHz
RF BLANKING/OFF (rear panel)	NORM
ALC Function Switch A1S1 Position 4	ON
ALC Function Switch A1S1 Position 5	OFF

RF Blanking

- c. Set power supply and function generator for zero output. Press 8620C CW pushbutton. Adjust 86290A for +5 dBm output power.
- d. Set 8620C MODE switch to AUTO, TRIGGER switch to EXT, and RF BLANKING/OFF switch (rear panel) to OFF. Press 8620C FULL SWEEP pushbutton.
- e. Set spectrum analyzer bandwidth to 10 kHz, scan width to 20 MHz/division, scan time to 5ms/division, and display sensitivity to 10 dB/division.
- f. Adjust spectrum analyzer to center RF carrier on display. Set reference level on spectrum analyzer. Set 8620C RFBLANKING/OFF switch to RF BLANKING and note difference in power level (ON/OFF ratio). ON/OFF ratio should be greater than 30 dB. Set RF BLANKING/OFF switch to OFF.

+5V Attenuation

- g. Check reference level on spectrum analyzer. Set power supply to +5 Vdc and note difference in power level (attenuation). Attenuation should be greater than 30 dB. Disconnect power supply from 8620C.

1 kHz Square Wave

- h. Calibrate oscilloscope for 10 dB/division sensitivity.

NOTE

The HP 8552B Spectrum Analyzer IF Section Vertical Output is calibrated to 10 dB/0.1 Vdc.

PERFORMANCE TESTS

4-15. AMPLITUDE MODUATION TEST (Cont'd)

- i. Set 8620C 1 kHz SQ WV/OFF switch to 1 kHz SQ WV. Set spectrum analyzer bandwidth to 300 kHz and scan width to zero. Note difference in power levels of ON and OFF periods as shown on oscilloscope. ON/OFF ratio should be greater than 25 dB. Set 8620C 1 kHz SQ WV/OFF to OFF.

27.8 kHz Square Wave

- j. Connect Function Generator to 8620C EXT AM input. Set Function Generator for 27.8 kHz and adjust for $\pm 6V$ output as shown on oscilloscope. Note difference in power levels of ON and OFF periods as shown on oscilloscope. ON/OFF ratio should be > 30 dB.

Symmetry

- k. Observe ON period to OFF period ratio on oscilloscope. ON/OFF symmetry should be $> 45/55$.

4-16. FREQUENCY REFERENCE OUTPUT TEST

REFERENCE:

Paragraph 5-29, FREQUENCY REFERENCE CALIBRATION ADJUSTMENT.

DESCRIPTION:

Rear-panel FREQ REF connector is checked with a Digital Voltmeter at several points across the band with 8620C in Band 4, CW Operation, for voltage accuracy.

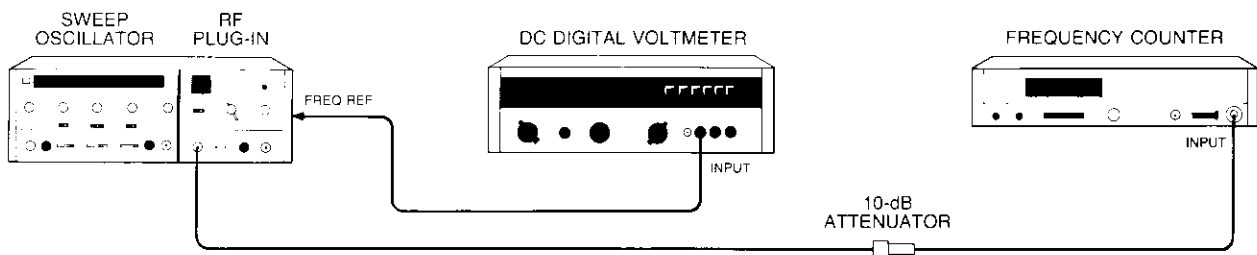

Figure 4-21. Frequency Reference Output Test Setup

EQUIPMENT:

Sweep Oscillator	HP 8620C
RF Plug-in	HP 86290A
DC Digital Voltmeter	HP 3460B
Frequency Counter	HP 5340A
10-dB Attenuator	HP 8491B, Option 010

PROCEDURE:

- a. Connect equipment as shown in Figure 4-21.

PERFORMANCE TESTS

4-16. FREQUENCY REFERENCE OUTPUT TEST (Cont'd)

- b. Press 8620C LINE pushbutton ON. Press CW and CW VERNIER pushbuttons. Select Band 4.
- c. Adjust CW MARKER and CW VERNIER controls for frequency counter indication of 4.000 GHz ± 0.001 GHz. DVM indication should be 4.000 Vdc ± 0.002 Vdc.
- d. Adjust CW MARKER and CW VERNIER controls for frequency counter indication of 8.000 GHz ± 0.001 GHz. DVM indication should be 8.000 Vdc ± 0.002 Vdc.
- e. Adjust CW MARKER and CW VERNIER controls for frequency counter indication of 12.000 GHz ± 0.001 GHz. DVM indication should be 12.00 Vdc ± 0.002 Vdc.
- f. Adjust CW MARKER and CW VERNIER controls for frequency counter indication of 16.000 GHz ± 0.001 GHz. DVM indication should be 16.000 Vdc ± 0.002 Vdc.

Table 4-18. Model 86290A Performance Test Record (1 of 5)

Hewlett-Packard Model 86290A RF Plug-in Serial Number: _____				
Test Performed by: _____				
Date: _____				
PARA. NO.	DESCRIPTION	LOWER LIMIT	MEASURED VALUE	UPPER LIMIT
48.	FREQUENCY RANGE AND ACCURACY TEST			
	<i>CW Mode Accuracy</i>			
	d. CW MARKER pointer set to low-frequency end of each band (Table 4-2).			
	Band 1	1.980 GHz	_____	2.020 GHz
	Band 2	5.980 GHz	_____	6.020 GHz
	Band 3	11.980 GHz	_____	12.020 GHz
	Band 4	1.920 GHz	_____	2.080 GHz
	e. CW MARKER pointer set to middle of each band (Table 4-3).			
	Band 1	4.080 GHz	_____	4.120 GHz
	Band 2	9.180 GHz	_____	9.220 GHz
	Band 3	14.980 GHz	_____	15.020 GHz
	Band 4	9.920 GHz	_____	10.080 GHz
	f. CW MARKER pointer set to high-frequency end of each band (Table 4-4).			
	Band 1	6.180 GHz	_____	6.220 GHz
	Band 2	12.380 GHz	_____	12.420 GHz
	Band 3	17.980 GHz	_____	18.020 GHz
	Band 4	17.920 GHz	_____	18.080 GHz
	<i>Manual Sweep Accuracy</i>			
	g. START MARKER pointer at low-frequency end of each band (Table 4-5).			
	Band 1	1.970 GHz	_____	2.030 GHz
Band 2	5.970 GHz	_____	6.030 GHz	
Band 3	11.970 GHz	_____	12.030 GHz	
Band 4	1.920 GHz	_____	2.080 GHz	

Table 4-18. Model 86290A Performance Test Record (2 of 5)

PARA. NO.	DESCRIPTION	LOWER LIMIT	MEASURED VALUE	UPPER LIMIT
4-8.	FREQUENCY RANGE AND ACCURACY TEST (Cont'd)			
	h. STOP MARKER pointer at high-frequency end of each band (Table 4-6).			
	Band 1	6.170 GHz	_____	6.230 GHz
	Band 2	12.370 GHz	_____	12.430 GHz
	Band 3	17.970 GHz	_____	18.030 GHz
	Band 4	17.920 GHz	_____	18.080 GHz
	<i>Swept Frequency Endpoint Accuracy (Table 4-7)</i>			
	m. Band 1 Low		_____	±30 MHz
	Band 1 High		_____	±30 MHz
	n. Band 2 Low		_____	±30 MHz
	Band 2 High		_____	±30 MHz
	Band 3 Low		_____	±30 MHz
	Band 3 High		_____	±30 MHz
	Band 4 Low		_____	±80 MHz
	Band 4 High		_____	±80 MHz
	<i>Marker Accuracy (Table 4-8)</i>			
	r. Band 1	4.070 GHz	_____	4.130 GHz
	s. Band 2	9.170 GHz	_____	9.230 GHz
	Band 3	14.970 GHz	_____	15.030 GHz
	Band 4	9.920 GHz	_____	10.080 GHz
4-9.	FREQUENCY STABILITY TEST			
	<i>Frequency Change with Temperature (Table 4-10) 0°C to 55°C</i>			
	d. Band 1	-0.5 MHz/°C	_____	+0.5 MHz/°C
	Band 2	-1.0 MHz/°C	_____	-1.0 MHz/°C
	Band 3	-1.5 MHz/°C	_____	-1.5 MHz/°C
	Band 4	-2.0 MHz/°C	_____	-2.0 MHz/°C
	<i>Frequency Change with Line Voltage</i>			
	f. Line voltage 103 Vac (Table 4-10).			
	Band 1	-100 kHz	_____	+100 kHz
	Band 2	-100 kHz	_____	+100 kHz
Band 3	-100 kHz	_____	+100 kHz	
Band 4	-100 kHz	_____	+100 kHz	

Table 4-18. Model 86290A Performance Test Record (3 of 5)

PARA. NO.	DESCRIPTION	LOWER LIMIT	MEASURED VALUE	UPPER LIMIT	
4-9.	FREQUENCY STABILITY TEST (Cont'd)				
	g. Line voltage 127 Vac (Table 4-10).				
	Band 1	-100 kHz	_____	+100 kHz	
	Band 2	-100 kHz	_____	+100 kHz	
	Band 3	-100 kHz	_____	+100 kHz	
	Band 4	-100 kHz	_____	+100 kHz	
	<i>Frequency Change with Power Level Change (Table 4-11)</i>				
	j. Band 1	-200 kHz	_____	+200 kHz	
	k. Band 2	-400 kHz	_____	+400 kHz	
	Band 3	-600 kHz	_____	+600 kHz	
	Band 4	-600 kHz	_____	+600 kHz	
	<i>Frequency Change with 3:1 Load SWR (Table 4-12).</i>				
	q. Band 1	-100 kHz	_____	+100 kHz	
	r. Band 2	-200 kHz	_____	+200 kHz	
	Band 3	-300 kHz	_____	+300 kHz	
	Band 4	-300 kHz	_____	+300 kHz	
	<i>Residual FM (Table 4-13)</i>				
	w. Band 1		_____	±10 kHz	
	x. Band 2		_____	±20 kHz	
	Band 3		_____	±30 kHz	
Band 4		_____	±30 kHz		
4-10.	POWER LEVEL AND VARIATION TEST				
	<i>Internal Leveling</i>				
	d. CW minimum power.	+5.0 dBm	_____		
	j. Internal leveling variation (Table 4-15).				
	Band 1		_____	±0.7 dB	
	Band 2		_____	±0.7 dB	
	Band 3		_____	±0.8 dB	
	Band 4		_____	±0.9 dB	
	<i>Crystal Detector Leveling</i>				
	o. Variation limits.		_____	±0.15 dB	

Table 4-18. Model 86290A Performance Test Record (4 of 5)

PARA. NO.	DESCRIPTION	LOWER LIMIT	MEASURED VALUE	UPPER LIMIT
4-10.	POWER LEVEL AND VARIATION TEST (Cont'd) <i>Power Meter Leveling</i> v. Variation limits.		_____	±0.15 dB
4-11.	RESIDUAL AM TEST d. Below fundamental at specified maximum power.	55 dB	_____	
4-12.	SPURIOUS SIGNALS TEST e. Harmonically related signals. e. Nonharmonics.	25 dB 50 dB	_____ _____	
4-13.	EQUIVALENT SOURCE SWR TEST c. Source match SWR.		_____	1.9
4-14.	EXTERNAL FREQUENCY MODULATION TEST <i>Low Frequency FM (Table 4-16)</i> f. Deviation with 10 Hz modulation frequency. Band 1 Band 2 Band 3 Band 4 g. Deviation with 100 Hz modulation frequency. Band 1 Band 2 Band 3 Band 4	±75 MHz ±75 MHz ±75 MHz ±75 MHz ±75 MHz ±75 MHz ±75 MHz ±75 MHz	_____ _____ _____ _____ _____ _____ _____ _____	

Table 4-18. Model 86290A Performance Test Record (5 of 5)

PARA. NO.	DESCRIPTION	LOWER LIMIT	MEASURED VALUE	UPPER LIMIT
4-14.	<p>EXTERNAL FREQUENCY MODULATION TEST (Cont'd) <i>High Frequency FM (Table 4-17).</i> 1. Deviation with 900 kHz modulation frequency. (See Figure 4-18.)</p> <p style="padding-left: 40px;">Band 1</p> <p style="padding-left: 40px;">Band 2</p> <p style="padding-left: 40px;">Band 3</p> <p style="padding-left: 40px;">Band 4</p> <p>m.Deviation with 2.1 MHz modulation frequency (See Figure 4-19.)</p> <p style="padding-left: 40px;">Band 1</p> <p style="padding-left: 40px;">Band 2</p> <p style="padding-left: 40px;">Band 3</p> <p style="padding-left: 40px;">Band 4</p>	<p>Correct Waveform</p> <p>Correct Waveform</p> <p>Correct Waveform</p> <p>Correct Waveform</p> <p>Correct Waveform</p> <p>Correct Waveform</p> <p>Correct Waveform</p> <p>Correct Waveform</p>	<p>_____</p> <p>_____</p> <p>_____</p> <p>_____</p> <p>_____</p> <p>_____</p> <p>_____</p> <p>_____</p>	
4-15.	<p>AMPLITUDE MODULATION TEST f. RF Blanking ON/OFF Ratio g. +5V Attenuation i. 1 kHz Square Wave ON/OFF Ratio j. 27.8 kHz Square Wave ON/OFF Ratio k. Symmetry</p>	<p>30 dB</p> <p>30 dB</p> <p>25 dB</p> <p>30 dB</p>	<p>_____</p> <p>_____</p> <p>_____</p> <p>_____</p>	
4-16.	<p>FREQUENCY REFERENCE OUTPUT TEST c. CW MARKER pointer to 4.000 GHz. FREQ REF Voltage d. CW MARKER pointer to 8.000 GHz. FREQ REF Voltage e. CW MARKER pointer to 12.000 GHz. FREQ REF Voltage f. CW MARKER pointer to 16.000 GHz. FREQ REF Voltage</p>	<p>3.998 Vdc</p> <p>7.998 Vdc</p> <p>11.998 Vdc</p> <p>15.998 Vdc</p>	<p>_____</p> <p>_____</p> <p>_____</p> <p>_____</p>	<p>4.002 Vdc</p> <p>8.002 Vdc</p> <p>12.002 Vdc</p> <p>16.002 Vdc</p>

SECTION V ADJUSTMENTS

5-1. INTRODUCTION

5-2. This section provides adjustment procedures for the Model 86290A RF Plug-in. These procedures should not be performed as a routine maintenance procedure, but should be used (1) after replacement of a part or component, (2) when performance tests show that the specifications of Table 1-1 cannot be met, or (3) when instructed to do so in the troubleshooting chart in Section VIII. Before attempting any adjustment, allow 30 minutes warm-up time for the instrument. Table 5-1 lists the adjustment controls and the function of each control. The Factory Selected Components are listed in reference designator order in Table 5-2.

5-3. EQUIPMENT REQUIRED

5-4. Table 1-3 lists the equipment required for the adjustment procedure. If the test equipment recommended is not available, other equipment may be used if its performance meets the "Critical Specifications" listed in the table. The test setup used for an adjustment procedure is referenced in each procedure.

5-5. FACTORY SELECTED COMPONENTS

5-6. Factory selected components can be recognized by an asterisk on the schematic diagram. The range of values and functions are listed in Table 5-2. Selection of these component values is covered in the adjustment procedures. The exact values of the components selected for the YTM and YTO assemblies are recorded on the RF Section casting.

5-7. SAFETY CONSIDERATIONS

5-8. Although this instrument has been designed in accordance with international safety standards, this manual contains information, cautions, and warnings which must be followed to ensure safe operation and to retain the instrument in safe condition (see Sections II and III). Service and adjustments should be performed only by qualified service personnel.

WARNING

Any interruption of the protective (grounding) conductor (inside or outside the instrument) or disconnecting the protective earth terminal could make this instrument dangerous. Intentional interruption is prohibited.

5-9. Any adjustment, maintenance, and repair of the opened instrument under voltage should be avoided as much as possible and, when required, should be performed only by skilled persons who are aware of the hazard involved.

5-10. Capacitors inside the instrument may still be charged even if the instrument has been disconnected from its source of supply.

5-11. Make sure that only fuses with the required rated current and of the specified type (normal blow, time delay, etc.) are used for replacement. The use of repaired fuses and the shortcircuiting of fuseholders must be avoided.

5-12. Whenever it is likely that the protection offered by fuses has been impaired, the instrument must be made inoperative and be secured against any unintended operation.

WARNING

Adjustments described herein are performed with power supplied to the instrument while protective covers are removed. Energy available at many points may, if contacted, result in personal injury.

5-13. RELATED ADJUSTMENTS

5-14. Interactive control adjustments are noted in the procedures. Table 5-3 indicates by paragraph numbers the adjustments that must be performed if an assembly has been replaced or repaired, or if an adjustment has been made on an assembly.

OSCILLATOR

S/N _____

IS INSTALLED IN THIS INSTRUMENT. SELEC-
TED VALUES FOR A3
YTO DRIVER BOARD
ARE:

R 46 _____

R 47 _____

R 48 _____

R 49 _____

R 59 _____

MADE IN U.S.A.

MULTIPLIER

S/N _____

IS INSTALLED IN THIS INSTRUMENT. SELEC-
TED VALUES FOR A2
YTM DRIVER BOARD
ARE:

R 60 _____

R 65 _____

R 73 _____

R 74 _____

R 76 _____

R 79 _____

MADE IN U.S.A.

R F ALIGNMENT PROCEDURE

NOTE: This is an abbreviated procedure. For complete adjustment procedures, see Section V in Operating and Service Manual. Allow 30 minute warmup before adjustment. For tracking adjustment only, go directly to step 2.

1. FREQUENCY ACCURACY, A3 BOARD ADJUSTMENTS

Monitor AUX OUT frequency with counter. Select specified band. Adjust CW and CW VERNIER for indicated voltage between 86290A A5TP1 and 8620A/B A4 GND REF. Adjust specified controls at top of A3 board for indicated AUX OUT frequency. Always adjust LO control first.

BAND	A5TP1 (VOLTS)	A3 BOARD ADJUSTMENTS	AUX OUT FREQUENCY
1	0.000	Band 1 LO	2.000 GHz
1	10.000	Band 1 HI	6.200 GHz
2	0.000	Band 2 LO	3.000 GHz
2	10.000	Band 2 HI	6.200 GHz
3	0.000	Band 3 LO	4.000 GHz
3	10.000	Band 3 HI	6.000 GHz

2. TRACKING, A2 BOARD ADJUSTMENTS

Set PEAK control to mechanical center. Monitor unlevelled RF OUTPUT power with swept display or power meter. Select BAND 1, 2.0 - 6.2 GHz, and adjust BAND 1 LO control at top of A2 board for maximum power over lower portion of band. Then adjust BAND 1 HI control for maximum power over upper portion of band. Repeat procedure for BAND 2 and BAND 3. Always adjust LO control first.

MADE IN U.S.A.

Figure 5-1. RF Section Labels for YTO and YTM Factory Selected Components and Abbreviated RF Alignment Procedure

Table 5-1. Controls Listed in Adjustment Sequence (1 of 2)

Adj. Para.	Ref. Des.	Schematic Name	Function
5-19	A4R16	BAL	Adjusts for zero frequency offset
5-20	A5R24	OFFSET ADJ	Adjusts for zero frequency control voltage offset at low end of Band 1.
5-20	A5R22	BAND 1 HI	Adjusts for frequency control voltage of 10.000 Vdc at high end of Band 1.
5-20	A5R10	BAND 2 B	Adjusts frequency control voltage in Band 2.
5-20	A5R13	BAND 2 A	Adjusts frequency control voltage in Band 2.
5-20	A5R2	BAND 3 B	Adjusts frequency control voltage in Band 3.
5-20	A5R7	BAND 3 A	Adjusts frequency control voltage in Band 3.
5-21	A6R2	LO	Adjusts 6.2 GHz switchpoint.
5-21	A6R6	HI	Adjusts 12.4 GHz switchpoint.
5-22	A3R33	ZERO	Adjusts Band Switch Amplifier A3U2 offset voltage.
5-22	A3R4	BAND 1 LO	Adjusts low-end frequency of Band 1.
5-22	A3R6	BAND 2 LO	Adjusts low-end frequency of Band 2.
5-22	A3R8	BAND 3 LO	Adjusts low-end frequency of Band 3.
5-22	A3R3	BAND 1 HI	Adjusts high-end frequency of Band 1.
5-22	A3R5	BAND 2 HI	Adjusts high-end frequency of Band 2.
5-22	A3R7	BAND 3 HI	Adjusts high-end frequency of Band 3.
5-23	A2R27	ZERO	Adjusts Band Switch Amplifier A2U1 offset voltage.
5-23	A2R2	BAND 1 LO	Adjusts for maximum power at low-end of Band 1.
5-23	A2R1	BAND 1 HI	Adjusts for maximum power at high end of Band 1.
5-23	A2R4	BAND 2 LO	Adjusts for maximum power at low end of Band 2.
5-23	A2R3	BAND 2 HI	Adjusts for maximum power at high end of Band 2.
5-23	A2R39	BAND 2 LO BIAS	Adjusts for maximum power across Band 2.
5-23	A2R38	BAND 2 HI BIAS	Adjusts for maximum power across Band 2.
5-23	A2R6	BAND 3 LO	Adjusts for maximum power at low end of Band 3.
5-23	A2R5	BAND 3 HI	Adjusts for maximum power at high end of Band 3.
5-23	A2R41	BAND 3 LO BIAS	Adjusts for maximum power across Band 3.
5-23	A2R40	BAND 3 HI BIAS	Adjusts for maximum power across Band 3.
5-24	A10A1R4	OFFSET	Adjusts YTM Bias for maximum power in Bands 2 and 3.
5-24	A11A1R7	FSA	Adjusts for optimum match between amplifier and modulator.
5-25	A2R32	M_O	Adjusts magnitude of delay compensation offset.
5-25	A2R31	M_S	Adjusts magnitude of delay compensation slope.
5-25	A2R25	t_s	Adjusts risetime of delay compensation slope.

Table 5-1. Controls Listed in Adjustment Sequence (2 of 2)

Adj. Para.	Ref. Des.	Schematic Name	Function
5-25	A2R26	t_0	Adjusts risetime of delay compensation offset.
5-25	A3R34	M_{01}	Adjusts magnitude of delay compensation offset in Band 1.
5-25	A3R41	M_{s1}	Adjusts magnitude of delay compensation slope in Band 1.
5-25	A3R38	t_{s1}	Adjusts risetime of delay compensation slope in Band 1.
5-25	A3R30	t_{01}	Adjusts risetime of delay compensation offset in Band 1.
5-25	A3R36	M_{03}	Adjusts magnitude of delay compensation offset in Band 3.
5-25	A3R43	M_{s3}	Adjusts magnitude of delay compensation slope in Band 3.
5-25	A3R40	t_{s3}	Adjusts risetime of delay compensation slope in Band 3.
5-25	A3R32	t_{03}	Adjusts risetime of delay compensation offset in Band 3.
5-25	A2R55	COMP BREAK POINT	Adjusts frequency at which fade-in compensation is activated.
5-25	A2R57	COMP MAG	Adjusts magnitude of fade-in compensation.
5-25	A2R67	TIME 2	Adjusts for sweep speed related power variations in Band 2 portion of Band 4.
5-25	A2R68	TIME 3	Adjusts for sweep speed related power variations in Band 3 portion of Band 4.
5-26	A1R60	SYMMETRY	Optimizes 30 kHz square wave shape.
5-26	A1R7	LO LEVEL CLAMP	Sets power at maximum CCW setting of front-panel POWER LEVEL control.
5-26	A1R29	F1	Adjusts flatness at low end of band.
5-26	A1R36	G1	Adjusts flatness at low end of band.
5-26	A1R42	F2	Adjusts flatness at high end of band.
5-26	A1R55	G2	Adjusts flatness at high end of band.
5-26	A1R75	PIN UPPER CLAMP	Sets maximum available current to modulator.
5-26	A1R71	GAIN SHAPING	Adjusts flatness across band with no oscillations.
5-26	A1R10	UPPER POWER CLAMP	Sets power at most CW setting of front-panel POWER LEVEL control with internal A1S1 position #3 OFF.
5-26	A1R59	GAIN PRESET	Sets range of front-panel ALC GAIN control.
5-28	A6R2	LO	Adjusts 6.2 GHz switchpoint.
5-28	A5R22	HI	Adjusts 6.2 GHz switchpoint.
5-28	A6R6	HI	Adjusts 12.4 GHz switchpoint.
5-28	A5R2	B	Adjusts 12.4 GHz switchpoint.
5-29	A3R63	C	Offsets FREQ REF output voltage.
5-29	A3R55	B	Adjusts FREQ REF output voltage at high end.
5-30	A4R46	NO NAME	Selected for YTO/YTO Driver sensitivity match.

Table 5-2. Factory Selected Components

Ref. Desig.	Function	Range of Values
*A2R60	Coarse adjustment of YTM reference resistor	100 – 2000 ohms
*A2R65	Coarse adjustment of YTM reference resistor for lower end of frequency range.	500 – 25K ohms
*A2R73	Linearity Compensation	5000 ohms – open
*A2R74	Linearity Compensation	5000 ohms – open
*A2R76	Linearity Compensation	5000 ohms – open
*A2R79	Linearity Compensation	5000 ohms – open
*A3R46	Linearity Compensation	50K – 1M ohms
*A3R47	Linearity Compensation	10K – 100K ohms
*A3R48	Linearity Compensation	10K – 100K ohms
*A3R49	Linearity Compensation	50K – 1M ohms
*A3R59	Coarse Frequency Adjustment	100 – 5000 ohms
A4R46	FM Sensitivity Adjustment	13.3 – 316 Ohms

*Actual value selected is recorded on RF Section casting.

Table 5-3. Adjustments By Assemblies

Assembly Changed	Adjustment Sections to be Performed
A1	5-20
A2	5-16 through 5-24
* A3	5-16 through 5-24
A4	5-13 and 5-24
A5	5-14, 5-22, and 5-23
A6	5-15
A7	No adjustment necessary
A8	No adjustment necessary
* A9	5-16 through 5-24
A10	5-18 and 5-20
A11	5-18 and 5-20
A12	5-18 and 5-20
AT1	No adjustment necessary
CR1	5-20
DC1	5-20

*NOTE: Assemblies A3 and A9 replaced together. Order HP Part Number 86290-60022.

5-15. ABBREVIATED RF ALIGNMENT PROCEDURE

5-16. An abbreviated RF alignment procedure is attached to the casting of the RF Section. This procedure may be used in lieu of the complete tracking and frequency adjustments in paragraphs 5-22 and 5-23. It could be used when (1) there is a decrease in CW power, (2) power decreases when changing sweep speeds, or (3) when the PEAK control does not have enough range to optimize output power. Changes in frequency accuracy may also be corrected with this

procedure. Use of this abbreviated procedure is to be limited to minor adjustments only. If the indications point to extensive trouble, see the complete adjustment procedures or refer to Section VIII for service and troubleshooting. Figure 5-1 shows the abbreviated RF alignment procedure.

5-17. LOCATION OF TEST POINTS AND ADJUSTMENTS

5-18. For location of adjustments and test points, refer to Figures 5-22 through 5-26.

ADJUSTMENTS

5-19. FREQUENCY MODULATION BALANCE ADJUSTMENT

REFERENCE:

SERVICE SHEET 4, FREQUENCY MODULATION ASSEMBLY.

DESCRIPTION:

Sets voltages to establish zero frequency offset.

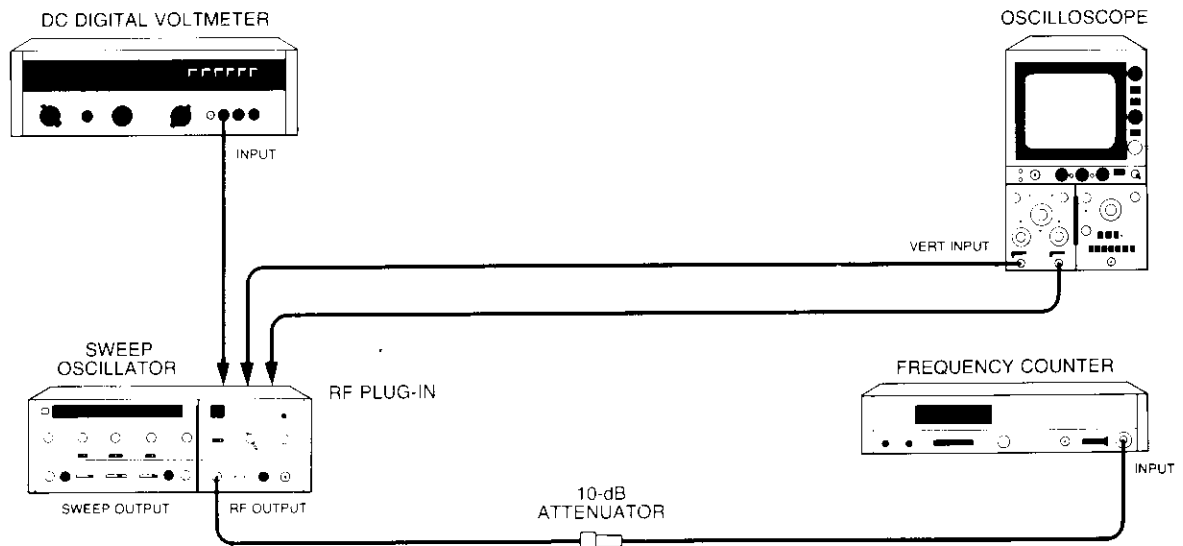

Figure 5-2. Adjustment Test Setup

ADJUSTMENTS

see change, page 7-2

5-19. FREQUENCY MODULATION BALANCE ADJUSTMENT (Cont'd)

Replace par. 5-19 with par. 7-7 page 7-7

EQUIPMENT:

Sweep Oscillator	HP 8620C
RF Plug-in	HP 86290A
DC Digital Voltmeter	HP 3460B
Frequency Counter	HP 5340A
Oscilloscope	HP 182C/1801A/1820C
10-dB Attenuator	HP 8491B, Option 010

PROCEDURE:

- a. Press 8620C LINE switch to ON; allow 30 minutes warm-up time.
- b. Press 8620C CW pushbutton.
- c. Connect digital voltmeter to A4TP2 and connect ground to A4TP4. Adjust A4 Bal control A4R16 for digital voltmeter indication of 0.00 Vdc \pm 0.01 Vdc.

5-20. SWEEP CONTROL ADJUSTMENTS

REFERENCE:

SERVICE SHEET 5, SWEEP CONTROL ASSEMBLY.

DESCRIPTION:

Set ramp voltages to establish proper frequencies.

EQUIPMENT:

Use test setup in Figure 5-2.

PROCEDURE:

- a. Select Band 1. Press CW and CW VERNIER pushbuttons. Set NORM-CAL switch A5S1, at top of A5 Sweep Control Board, to CAL (towards front panel).
- b. Connect digital voltmeter to A5TP1; ground lead to A5TP3 (FREQ REF GND). Adjust 8620C CW MARKER and CW VERNIER controls for digital voltmeter indication of 0.000 Vdc \pm 0.001 Vdc.
- c. Connect digital voltmeter to A5TP2. Adjust A5 Offset Adj A5R24 for 0.000 Vdc \pm 0.001 Vdc.
- d. Connect digital voltmeter to A5TP1. Adjust 8620C CW MARKER and CW VERNIER controls for +2.625 Vdc \pm 0.001 Vdc.

ADJUSTMENTS

5-20. SWEEP CONTROL ADJUSTMENTS (Cont'd)

- e. Connect digital voltmeter to A5TP2. Adjust A5 Band 1 HI A5R22 for $+10.000 \text{ Vdc} \pm 0.001 \text{ Vdc}$.
- f. Select Band 2.
- g. Connect digital voltmeter to A5TP1. Adjust 8620C CW MARKER and CW VERNIER controls for $+4.167 \text{ Vdc} \pm 0.001 \text{ Vdc}$.
- h. Connect digital voltmeter to A5TP2. Adjust A5 Band 2 B A5R10 for $+4.167 \text{ Vdc} \pm 0.001 \text{ Vdc}$.
- i. Connect digital voltmeter to A5TP1. Adjust 8620C CW MARKER and CW VERNIER controls for $+6.500 \text{ Vdc} \pm 0.001 \text{ Vdc}$.
- j. Connect digital voltmeter to A5TP2. Adjust A5 Band 2 A A5R13 for $+10.000 \text{ Vdc} \pm 0.001 \text{ Vdc}$.
- k. Repeat steps g through j to minimize errors due to control interactions.
- l. Select Band 3.
- m. Connect Digital voltmeter to A5TP1. Adjust 8620C CW MARKER and CW VERNIER controls for $+10.000 \text{ Vdc} \pm 0.001 \text{ Vdc}$.
- n. Connect digital voltmeter to A5TP2. Adjust A5 Band 3 B A5R2 for $+10.000 \text{ Vdc} \pm 0.001 \text{ Vdc}$.
- o. Connect digital voltmeter to A5TP1. Adjust 8620C CW MARKER and CW VERNIER controls for $+6.500 \text{ Vdc} \pm 0.001 \text{ Vdc}$.
- p. Connect digital voltmeter to A5TP2. Adjust A5 Band 3 A A5R7 for $+0.667 \text{ Vdc} \pm 0.001 \text{ Vdc}$.
- q. Repeat steps m through p to minimize errors due to control interactions.
- r. Set 86290A NORM-CAL switch A5S1 to NORM position.
- s. Connect digital voltmeter to A5TP1. Adjust 8620C CW MARKER and CW VERNIER controls for $0.000 \text{ Vdc} \pm 0.001 \text{ Vdc}$.
- t. Connect digital voltmeter to A5TP2. Digital voltmeter should indicate $0.000 \text{ Vdc} \pm 0.005 \text{ Vdc}$ for 8620C set to Band 1, Band 2, and Band 3.
- u. Connect digital voltmeter to A5TP1. Adjust 8620C CW MARKER and CW VERNIER controls for $+10.000 \text{ Vdc} \pm 0.001 \text{ Vdc}$.
- v. Connect digital voltmeter to A5TP2. Digital voltmeter should indicate $+10.000 \text{ Vdc} \pm 0.005 \text{ Vdc}$ for 8620C set to Band 1, Band 2, and Band 3.

ADJUSTMENTS

5-21. STOP SWEEP ADJUSTMENTS

REFERENCE:

SERVICE SHEET 6, STOP SWEEP ASSEMBLY.

DESCRIPTION:

Adjust 86290A for proper sequential sweep operation.

EQUIPMENT:

Use Test setup in Figure 5-2.

PROCEDURE:

- a. Set controls as follows:

8620C:

BAND	Band 4
MODE	AUTO
TRIGGER	INT
TIME-SECONDS1 — .01
TIME-SECONDS Vernier	Fully clockwise

- b. Press 8620C LINE pushbutton ON. Press CW pushbutton. Set CW MARKER to low-end of scale.
- c. Connect digital voltmeter to A6TP5; ground lead to A5TP3 (FREQ REF GND).
- d. Adjust A6 LO control A6R2 for digital voltmeter indication of $+2.625 \text{ Vdc} \pm 0.002 \text{ Vdc}$.
- e. Connect digital voltmeter to A6TP4. Adjust A6 HI control A6R6 for $+6.500 \text{ Vdc} \pm 0.002 \text{ Vdc}$.
- f. Press 8620C FULL SWEEP pushbutton. Connect oscilloscope Channel A to A6TP1 and Channel B to A6TP2. Display should appear as shown in Figure 5-3. Time durations shown are typical; actual times measured may vary slightly.

ADJUSTMENTS

5-21. STOP SWEEP ADJUSTMENTS (Cont'd)

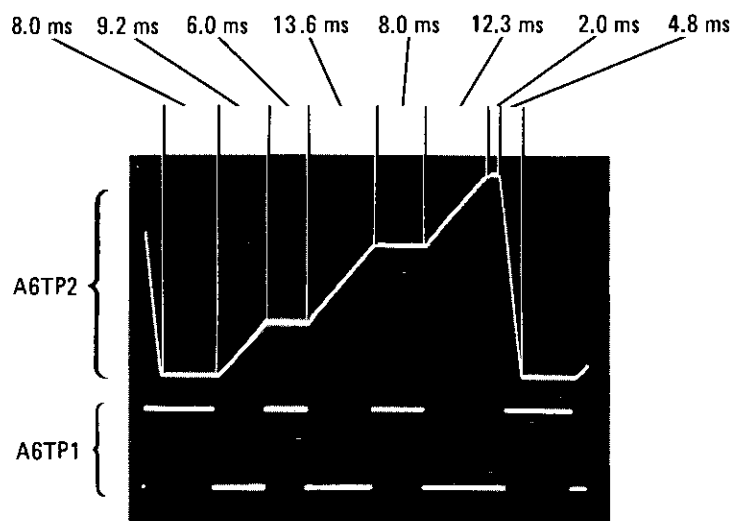

Figure 5-3. Stop Sweep Timing Waveform

5-22. YTO FREQUENCY RANGE ADJUSTMENTS

REFERENCE:

SERVICE SHEET 3, YIG TUNED OSCILLATOR DRIVER ASSEMBLY.

DESCRIPTION:

Set endpoint frequencies for each band.

EQUIPMENT:

Use adjustment test setup in Figure 5-2.

PROCEDURE:

NOTE

If A3 YTO Driver Assembly or A3U2 Band Switch Amplifier have been replaced, perform the following adjustment. If not, go to step a and proceed with YTO Frequency Adjustments.

- (1) With 8620C LINE switch OFF, remove A5 SWEEP CONTROL Assembly.
- (2) Press 8620C LINE switch ON.

ADJUSTMENTS

5-22. YTO FREQUENCY RANGE ADJUSTMENTS (Cont'd)

- (3) Connect DVM HIGH lead to A3TP1 and LOW lead to A3TP3.
 - (4) Adjust A2 ZERO control A2R33 for DVM indication of $0.0000 \text{ Vdc} \pm 0.0001 \text{ Vdc}$.
 - (5) Press 8620C LINE switch OFF. Reinstall A5 SWEEP CONTROL Assembly.
- a. Press 8620C LINE switch ON. Press CW and CW VERNIER pushbuttons. Select Band 1.
 - b. Connect digital voltmeter to A5TP1; ground lead to A5TP3 (FREQ REF GND).
 - c. Adjust CW MARKER and CW VERNIER controls for digital voltmeter indication of $0.000 \text{ Vdc} \pm 0.001 \text{ Vdc}$.
 - d. Adjust A3 Band 1 LO control A3R4 for a frequency counter indication of $2.000 \text{ GHz} \pm 1 \text{ MHz}$.
 - e. Select Band 2. Adjust A3 Band 2 LO control A3R8 for $6.000 \text{ GHz} \pm 1 \text{ MHz}$.
 - f. Select Band 3. Adjust A3 Band 3 LO control A3R26 for $12.000 \text{ GHz} \pm 1 \text{ MHz}$.
 - g. Adjust 8620C CW MARKER and CW VERNIER controls for a digital voltmeter indication of $+10.000 \text{ Vdc} \pm 0.001 \text{ Vdc}$.
 - h. Select Band 1. Adjust A3 Band 1 HI control A3R3 for a frequency indication of $6.200 \text{ GHz} \pm 1 \text{ MHz}$.
 - i. Select Band 2. Adjust A3 Band 2 HI control A3R7 for $12.400 \text{ GHz} \pm 1 \text{ MHz}$.
 - j. Select Band 3. Adjust A3 Band 3 HI control A3R25 for a frequency indication of $18.000 \text{ GHz} \pm 1 \text{ MHz}$.
 - k. Repeat steps c through j until adjustment errors between voltage and frequency readings are at a minimum.

5-23. YTM SLOW SPEED TRACKING ADJUSTMENTS

REFERENCE:

SERVICE SHEET 2, YIG TUNED MULTIPLIER DRIVER ASSEMBLY.

DESCRIPTION:

Adjusts YTM tracking for optimum power across all bands at slow sweep speeds.

ADJUSTMENTS

5-23. YTM SLOW SPEED TRACKING ADJUSTMENTS (Cont'd)

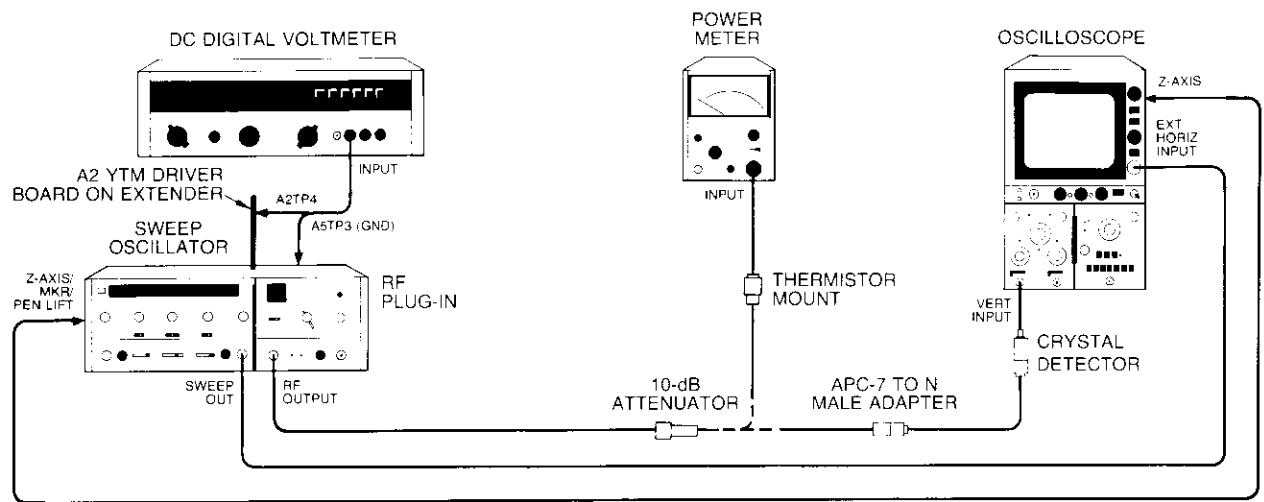

Figure 5-4. YTM Slow Speed Tracking Adjustment Test Setup

EQUIPMENT:

Sweep Oscillator	HP 8620C
RF Plug-in	HP 86290A
10-dB Attenuator	HP 8491B, Option 010
Power Meter	HP 432A
Thermistor Mount	HP 8478A
APC-7 to N Male Adapter	HP 11525A
Crystal Detector	HP 8470A
Oscilloscope	HP 182C/1801A/1820C

NOTE

The following procedure assumes YTO Frequency Range Adjustments in Paragraph 5-22 have been performed.

PROCEDURE:

- a. Set controls as follows:

8620C:

BAND	Band 3
MODE	AUTO
TRIGGER	INT
TIME-SECONDS1 — .01
TIME-SECONDS Vernier	Fully counterclockwise

ADJUSTMENTS

5-23. YTM SLOW SPEED TRACKING ADJUSTMENTS (Cont'd)

86290A:

RF	ON
ALC	INT
POWER LEVEL	Fully clockwise
PEAK	Midrange
SLOPE-OFF	OFF

NOTE

DO NOT change PEAK control setting during this adjustment.

NOTE

If A2 YTM Driver Assembly or A2U1 Band Change Amplifier have been replaced, perform the following adjustment. If not, go to step b and proceed with slow speed tracking adjustments.

YTM Tracking Offset Adjustment

- (1) Connect DVM as shown in Figure 5-4 with HIGH lead connected to A2TP1 and LOW lead to A2TP3.
 - (2) Remove A5 SWEEP CONTROL Assembly. Press 8620C LINE switch ON. Select Band 1.
 - (3) Adjust A2 ZERO control A2R27 for DVM indication of 0.0000 V dc \pm 0.0001 Vdc.
 - (4) Press 8620C LINE switch to OFF, Reinstall A5 SWEEP CONTROL Assembly. Press 8620C LINE switch ON. Select Band 3.
- b. Connect equipment as shown in Figure 5-4 with oscilloscope connected to 86290A RF OUTPUT. Install A2 YTM Driver Assembly on extender board (Figure 1-1). Set ALC Function switch A5S1 Position #3 Up (ON).

NOTE

If this adjustment is being performed due to replacement of A12 YTM assembly and new values for A2R60 and A2R65 are not known, proceed with step c. If new values for A2R60 and A2R65 are provided (See Figure 5-1), install new values and go to step i. If adjustment is being performed for reasons other than A12 YTM Assembly replacement, go directly to step i.

ADJUSTMENTS

5-23. YTM SLOW SPEED TRACKING ADJUSTMENTS (Cont'd)

- c. Set 86290A A2 controls as follows: (See Figure 5-25 for location of controls.)
- | | |
|--------------------------|----------------------------|
| to control | One-quarter turn clockwise |
| ts control | Midrange |
| Ms control | Fully counterclockwise |
| Mo control | Fully counterclockwise |
| COMP MAG control | Fully counterclockwise |
| COMP BREAK POINT control | Fully counterclockwise |
| Band 1 LO control | Midrange |
| Band 1 HI control | Midrange |
| Band 2 LO control | Midrange |
| Band 2 HI control | Midrange |
| Band 3 LO control | Midrange |
| Band 3 HI control | Midrange |
- d. Connect digital voltmeter to A2TP4; ground lead to A5TP3 (FREQ REF GND). Press 8620C LINE switch ON.
- e. Press 8620C CW pushbutton. Adjust CW MARKER control for digital voltmeter indication of 0.0 Vdc \pm 0.1 Vdc (approximately 16 GHz).
- f. Set 8620C MARKER switch to INTEN and press FULL SWEEP pushbutton.
- g. Replace A2R60 with a zero-to-2000 ohm 1% potentiometer. Adjust resistance (nominal value 1000 ohms) for maximum power at MARKER frequency. Measure resistance of potentiometer and replace with fixed-value resistor.
- h. Select Band 1. Replace A2R65 with a zero-to-50K ohm 1% potentiometer. Adjust resistance (nominal value 25K ohms) for optimum power across band. Measure resistance of potentiometer and replace with fixed-value resistor.
- i. Adjust A2 Band 1 LO control A2R2 for maximum power at low-frequency end of Band 1. Adjust A2 Band 1 HI control A2R1 for maximum power at high-frequency end of Band 1.
- j. Select Band 2. Adjust Band 2 LO control A2R4 for maximum power at low-frequency end of Band 2. Adjust A2 Band 2 HI control A2R3 for maximum power at high-frequency end of Band 2.
- k. Adjust A2 Band 2 LO Bias A2R39 and A2 Band 2 HI Bias A2R38 controls for maximum power across Band 2.
- l. Repeat steps j and k.
- m. Select Band 3. Adjust Band 2 LOW control A2R6 for maximum power at low frequency end of Band 3. Adjust Band 3 HI control A2R5 for maximum power at high-frequency end of Band 3.
- n. Adjust A2 Band 3 LO Bias A2R41 and A2 Band 3 HI Bias A2R40 controls for maximum power across Band 3.
- o. Repeat steps m and n.
- p. Disconnect oscilloscope and connect power meter to 86290A RF OUTPUT.

ADJUSTMENTS

5-23. YTM SLOW SPEED TRACKING ADJUSTMENTS (Cont'd)

- q. Set A5S1 ALC Function switch position # 3 Down (OFF).
- r. Adjust 86290A POWER LEVEL, PEAK, and SLOPE controls for maximum leveled power.
- s. Set 8620C MODE switch to MANUAL. Slowly rotate MANUAL control over full range while monitoring power meter indication.
- t. Minimum power point should be greater than +5 dBm.

NOTE

The following adjustments should be performed only when A10, A10A1, or A11 have been repaired or replaced.

5-24. YTM BIAS CONTROL AND AMPLIFIER FREQUENCY SELECTIVE ATTENUATOR (FSA) ADJUSTMENTS

see page 7-4 change

REFERENCE:

SERVICE SHEET 9, YTM BIAS CONTROL ASSEMBLY.

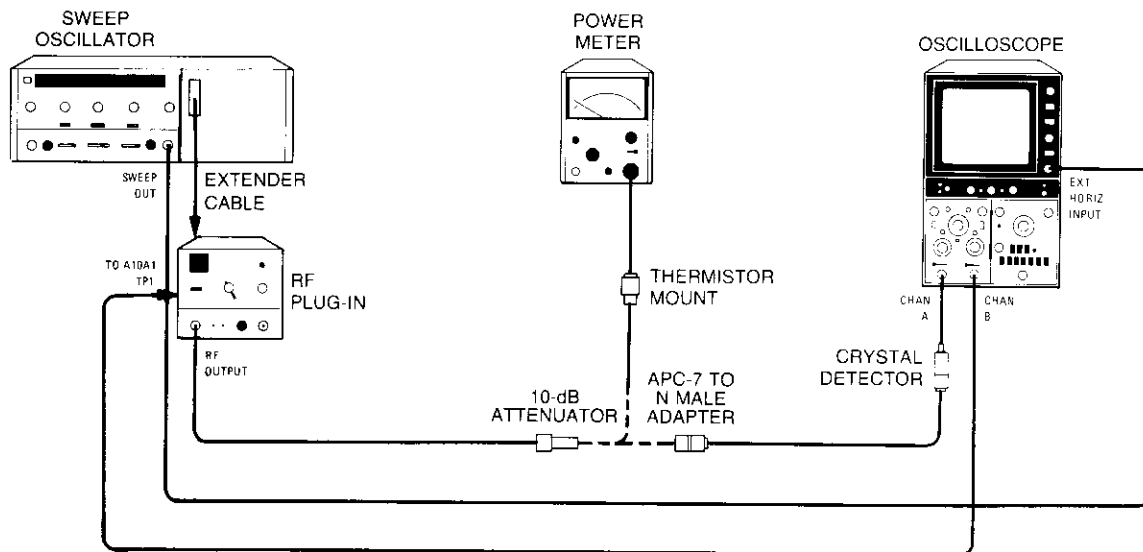

Figure 5-5. YTM Bias Control and FSA Adjustment Test Setup

DESCRIPTION:

Adjusts YTM bias control and frequency selective attenuator (FSA) voltages for optimum performance.

ADJUSTMENTS

5-24. YTM BIAS CONTROL AND AMPLIFIER FREQUENCY SELECTIVE ATTENUATOR (FSA) ADJUSTMENTS (Cont'd)

EQUIPMENT:

Sweep Oscillator	HP 8620C
RF Plug-in	HP 86290A
Power Meter	HP 432A
Thermistor Mount	HP 8478A
APC-7 to N Male Adapter	HP 11525A
Oscilloscope	HP 182C/1801A/1820C
10:1 Divider Probe	HP 10004A
10-dB Attenuator	HP 8491B, Option 010
Crystal Detector	HP 8470A
Extender Cable	HP 8620-60032

PROCEDURE:

- a. Remove RF section (see Figure 8-10).
- b. Remove cover plate from RF section to gain access to assemblies in RF section. Reconnect gray cable W2 to A1 board and blue cable W3 to A4 board and install A1, A2, A3, and A4 boards.
- c. With RF section on its side (exposed assemblies upward) and remaining part of Plug-in right side up, reconnect flexible cable W1 and reconnect cable W10 to rear of RF OUTPUT connector J1.
- d. Set controls as follows:

8620C:	
BAND	Band 4
MODE	AUTO
TRIGGER	INT
TIME-SECONDS1 — .01
TIME-SECONDS Vernier	Fully clockwise
86290A:	
RF	ON
ALC	INT
POWER-LEVEL	Twelve o'clock
- e. Connect equipment as shown in Figure 5-5 with oscilloscope, crystal detector, and 10-dB attenuator connected to RF OUTPUT. Press 8620C LINE switch to ON.
- f. Set POWER LEVEL control for maximum leveled power.

ADJUSTMENTS

5-24. YTM BIAS CONTROL AND AMPLIFIER FREQUENCY SELECTIVE ATTENUATOR (FSA) ADJUSTMENTS (Cont'd)

- g. Set PEAK control to obtain optimum flatness of signal displayed on CRT (18.0 GHz is the most critical point).
- h. Disconnect crystal detector and connect power meter/thermistor mount to 10-dB attenuator as shown in Figure 5-5.
- i. Press 8620C CW pushbutton and set 86290A POWER LEVEL control to obtain a power meter reading of approximately -15 dBm (-5 dBm at RF OUTPUT connector).
- j. With 10-dB attenuator and thermistor mount still connected to RF OUTPUT connector, connect oscilloscope Channel B input to A10A1TP1.
- k. Press 8620C MARKER SWEEP pushbutton and set OFFSET control A10A1R4 (Figure 8-40) fully clockwise.
- l. Adjust OFFSET control A10A1R4 counterclockwise until CRT trace is at maximum voltage in Bands 2 and 3 portion of Band 4 sweep. Display should appear as shown in Figure 5-6.
- m. Set oscilloscope vertical gain to most sensitive range and adjust vertical position control to center the display.
- n. Press 8620C MARKER SWEEP pushbutton. Set START MARKER pointer to 6.2 GHz and adjust OFFSET control A10A1R4 back and forth very slightly to insure that voltage at A10A1TP1 is maximum across entire display.
- o. Select Band 1. Set 8620C START MARKER Pointer to 2 GHz and STOP MARKER Pointer to 4 GHz.
- p. Set FSA control A11A1R7 (Figure 8-39) fully counterclockwise.
- q. Slowly adjust FSA control clockwise until a distinct sudden voltage level change occurs approximately between 2.2 GHz and 2.5 GHz on the CRT display (see Figures 5-7 and 5-8).
- r. Continue turning FSA control clockwise one full turn.
- s. Remove A1, A2, A3, and A4 boards. Disconnect gray cable W2 from A1 board and blue cable W3 from A4 board.
- t. Disconnect flexible cable W1 and RF cable W10.
- u. Install RF section in 86290A (see Figure 8-47).

ADJUSTMENTS

5-24. YTM BIAS CONTROL AND AMPLIFIER FREQUENCY SELECTIVE ATTENUATOR (FSA) ADJUSTMENTS (Cont'd)

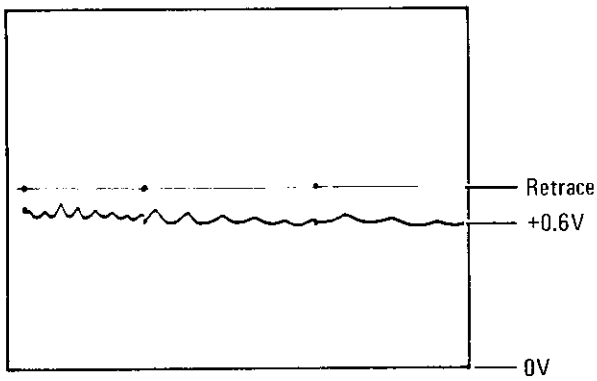

Figure 5-6. Pin Modulator Drive Voltage With Multiplier Bias Correctly Adjusted

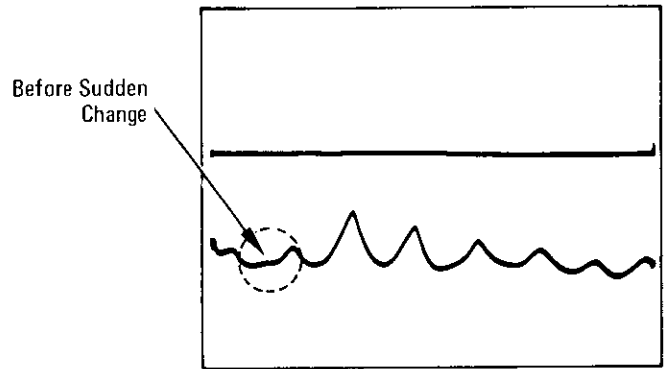

Figure 5-7. Pin Modulator Drive Voltage With FSA Counterclockwise

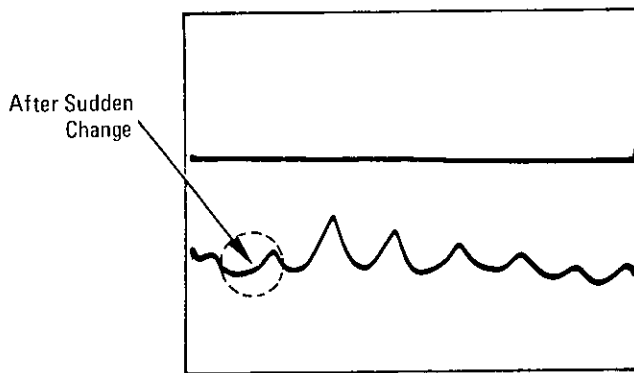

Figure 5-8. Pin Modulator Driver Voltage With FSA Correctly Adjusted

ADJUSTMENTS

5-25. YTM AND YTO DELAY COMPENSATION ADJUSTMENTS

REFERENCE:

SERVICE SHEET 2, YTM DRIVER ASSEMBLY.
 SERVICE SHEET 3, YTO DRIVER ASSEMBLY.

DESCRIPTION:

These adjustments compensate for the delay inherent in the magnetic circuits. Slope and offset controls provide lead or lag currents for the frequency control current applied to the YTO and YTM assemblies.

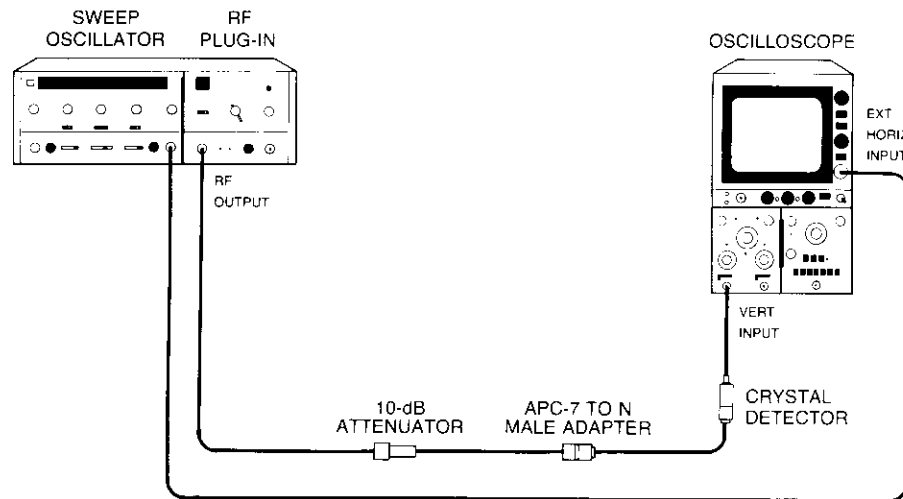

Figure 5-9. Delay Compensation Adjustment Test Setup

EQUIPMENT:

Sweep Oscillator	HP 8620C
Rf Plug-in	HP 86290A
Oscilloscope	HP 182C/1801A/1820C
10-dB Attenuator	HP 8491B, Option 010
APC-7 to N Male Adapter	HP 11525A
Crystal Detector	HP 8470A

ADJUSTMENTS

5-25. YTM AND YTO DELAY COMPENSATION ADJUSTMENTS (Cont'd)

PROCEDURE:

- a. Set 8620C controls as follows:

BAND	Band 2
MODE	AUTO
TRIGGER	INT
TIME-SECONDS1 — .01
TIME-SECONDS Vernier	Fully counterclockwise

- b. Press 8620C LINE switch ON. Adjust 86290A PEAK control for maximum output power.
- c. Slowly rotate 8620C TIME-SECONDS Vernier to fully clockwise position while observing oscilloscope display. Adjust A2 Mo control A2R32 to maintain constant power level at 3 divisions from left side of display.
- d. With 8620C TIME-SECONDS Vernier fully clockwise, adjust A2 Ms control A2R31 for maximum power across band.
- e. Vary TIME-SECONDS Vernier while observing power variations across band. Adjust A2 Ms control to minimize variations at high end of band and A2 ts control A2R25 to minimize variations at low end of band. Do not adjust for variations in first or last one-quarter division of display.
- f. Repeat steps c, d, and e to minimize power variations due to changes in sweep speed.
- g. Adjust A2 to control A2R26 to minimize power variations in first and last one-quarter divisions of display.
- h. Select Band 1.
- i. Set 8620C TIME-SECONDS Vernier fully counterclockwise. Adjust A2 Band 1 LO A2R2 and A2 Band 1 HI A2R1 controls for maximum power across band.
- j. Slowly rotate 8620C TIME-SECONDS Vernier fully clockwise while observing oscilloscope display. Adjust A3 Mo1 control A3R20 to maintain constant power level at 3 divisions from left side of display.
- k. Adjust A3Ms1 control A3R21 for maximum power across band.
- l. Vary TIME-SECONDS Vernier while observing power variations across band. Adjust A3 Ms1 control to minimize variations at high end of band and A3 ts1 control A3R6 to minimize variations at low end of band. Do not adjust for variations in first or last one-quarter division of display.
- m. Repeat steps j through l to minimize control interactions.
- n. Adjust A3 to 1 control A3R5 to minimize power variations in first and last one-quarter divisions of display.
- o. Select Band 3. Set TIME-SECONDS Vernier fully counterclockwise. Set 86290A A2 Comp Break Point A2R55 and A2 Comp Mag A2R57 controls fully counterclockwise.
- p. Adjust A2 Band 3 LO and A2 BAND 3 HI controls for maximum power across band.

ADJUSTMENTS

5-25. YTM AND YTO DELAY COMPENSATION ADJUSTMENTS (Cont'd)

- q. Slowly rotate 8620C TIME-SECONDS Vernier fully clockwise while observing oscilloscope display. Adjust A3 Mo3 control A3R34 to maintain constant power level at 3 divisions from left side of display.
- r. Adjust A3 Ms3 control A3R35 for maximum power across band.
- s. Vary TIME-SECONDS Vernier while observing power variations across band. Adjust A3 Ms3 control to minimize variations in center four divisions of display.
- t. Adjust A3 ts3 control A3R28 to minimize variations at low end of band. Disregard any high end variations.
- u. Repeat steps n through t to minimize control interactions. Adjust A3 to3 control A3R27 to minimize power variations in first and last one-quarter divisions of display.
- v. Set 8620C TIME-SECONDS Vernier fully counterclockwise. Note display on oscilloscope. Set TIME-SECONDS Vernier fully clockwise and note point where high-frequency end rolls off.
- w. Adjust A2 Comp Break Point control A2R55 clockwise to move compensation break point lower in frequency to point indicated in Figure 5-10.
- x. Adjust A2 Comp Mag control A2R57 to bring bottom trace up to coincide with top trace.

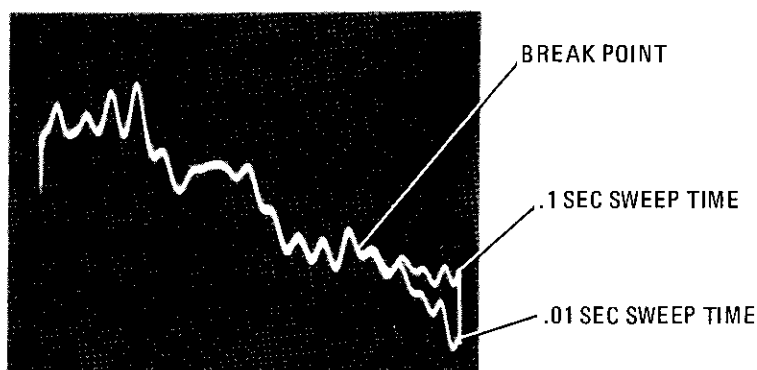

Figure 5-10. Fast Sweep Compensation Waveform

- y. Select Band 4 on 8620C. While varying TIME-SECONDS Vernier over full range, adjust A2 TIME 2 control A2R68 to minimize sweep speed related power variations in the Band 2 portion of the display. Adjust A2 TIME 3 control A2R67 to minimize power variations in the Band 3 portion of the display.
- z. Recheck sweep speed related power variations in all Bands. It may be necessary to readjust A2 TIME 2 and A2 TIME 3 controls so that best performance is achieved in all bands.

ADJUSTMENTS

5-26. ALC ADJUSTMENTS USING 8755A SWEEP AMPLITUDE ANALYZER

REFERENCE:

SERVICE SHEET 1. A1 ALC ASSEMBLY

DESCRIPTION:

A Model 8755A Swept Amplitude Analyzer is used to adjust HI and LO LEVEL CLAMP and SYMMETRY controls. SYMMETRY is adjusted so square-wave modulation is symmetrical over full range of POWER LEVEL and SLOPE controls. PIN UPPER CLAMP is adjusted for optimum flatness of oscilloscope trace. LO LEVEL CLAMP sets the minimum power level. Compensation Amplifier adjustments F1, F2, G1 and G2 are adjusted to cancel frequency dependence of the internal coupler and detector. GAIN SHAPING potentiometer is used to provide the best flatness without oscillations. UPPER POWER CLAMP is adjusted for maximum level power. GAIN PRESET adjustment is set so trace is free of oscillations over full rotation of POWER LEVEL control.

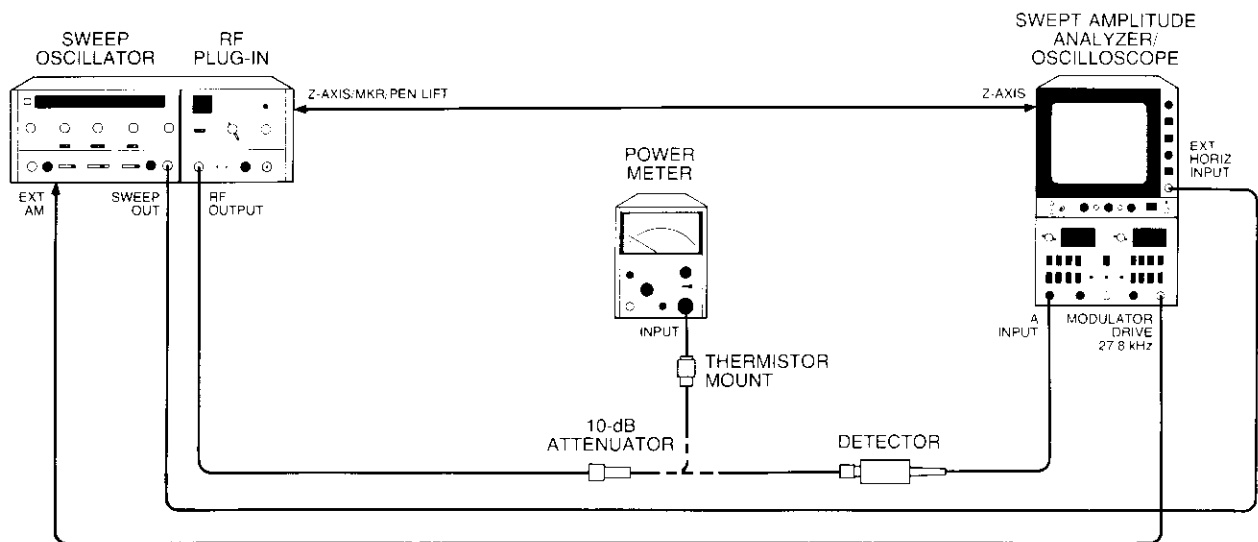

Figure 5-11. 8755A Calibration Test Setup

change 80-26 7-3

Replace par. 5-26 with par 7-8, page 7-9 ADJUSTMENTS

5-26. ALC ADJUSTMENTS USING 8755A SWEEP AMPLITUDE ANALYZER (Cont'd)

NOTE

Equipment listed is for four test setups, Figures 5-11, 5-12, 5-14 and 5-15. If equipment listed is not available, go to paragraph 5-27 and perform alternate ALC adjustments.

EQUIPMENT:

Sweep Oscillator	HP 8620C
RF Plug-in	HP 86290A
Oscilloscope	HP 182C/1801A/1820C
Sweep Amplitude Analyzer/Oscilloscope	HP 8755A/182C
Detector	HP 11664A
Power Meter	HP 432A
Thermistor Mount	HP 8478B
Crystal Detector	HP 8470A
APC-7 to N Male Adapter	HP 11525A
10-dB Attenuator	HP 8491B, Option 010
3-dB Attenuator	HP 8491B, Option 003
BNC TEE	HP 1250-0781

PROCEDURE:

1. 8755A Calibration

- a. Connect equipment as shown in Figure 5-11 with power meter connected to 86290A RF OUTPUT. Do not connect 8755A MODULATOR DRIVE to 8620C EXT AM input.

NOTE

If 8755A MODULATOR DRIVE is connected to 8620C EXT AM input, there will be a 3 dB error in the power meter indication.

- b. Set controls as follows:

8620C:
 BAND Band 4

86290A:
 RF ON-OFF ON
 ALC INT
 SLOPE OFF

8755A:
 OFFSET-CAL OFFSET (ON)
 OFFSET dB -10
 dB/DIV25
 DISPLAY A

 ADJUSTMENTS

5-26. ALC ADJUSTMENTS USING 8755A SWEEP AMPLITUDE ANALYZER (Cont'd)

- c. Press 8620C LINE pushbutton to ON. Press CW pushbutton. Set CW MARKER pointer to 2 GHz.
- d. Adjust 86290A POWER LEVEL control for power meter indication of -10 dB (0 dB minus 10-dB attenuator).
- e. Disconnect power meter. Connect 8755A A input to 86290A RF OUTPUT and MODULATOR DRIVE to 8620C EXT AM input.
- f. Using OFFSET control, adjust trace dot to center-line of 8755A CRT and mark position with grease pencil.
- g. Disconnect 8755A (including MODULATOR DRIVE). Connect power meter to 86290A RF OUTPUT.
- h. Set CW MARKER pointer to 4 GHz.
- i. Adjust 86290A POWER LEVEL control for power meter indication of -10 dB.
- j. Disconnect power meter. Connect 8755A A input to 86290A RF OUTPUT and MODULATOR DRIVE to 8620C EXT AM input.
- k. Mark position of trace dot on 8755A CRT with grease pencil.
- l. Repeat this process at 2 GHz intervals across full band.
- m. After 8755A CRT has been marked at 2 GHz intervals across full band, connect all marks, using grease pencil, to form a calibration line across CRT, representing the frequency response of the 8755A and 11664A Detector. This calibration line will be used to set 86290A RF OUTPUT flatness.

2. LO LEVEL CLAMP and SYMMETRY Adjustments

- a. Remove 86290A from mainframe. Remove A1 Board and disconnect gray cable W2 from A1J1. Remove extender board from bottom side of 86290A.
- b. Reinstall 86290A in mainframe. Reconnect W2 to A1J1 and install A1 Board on extender board.
- c. Preset adjustments as follows (Component Location, Figure 5-24).

A1 ALC Assembly:

PIN (PIN UPPER CLAMP)	Fully counterclockwise
SYMM (Symmetry)	Midrange
HI (UPPER LEVEL CLAMP)	Fully counterclockwise
LO (LO LEVEL CLAMP)	1/8th turn clockwise from midrange
F1 and F2	Four turns clockwise from fully counterclockwise
G1 and G2	Four turns clockwise from fully counterclockwise
GAIN SHAPING	Midrange
GAIN PRESET	Midrange

ADJUSTMENTS

5-26. ALC ADJUSTMENTS USING 8755A SWEPT AMPLITUDE ANALYZER (Cont'd)

ALC Function switch AIS1 (Figure 3-12):

- Position 1 (Down) OFF
- Position 2 (Down) OFF
- Position 3 (Up) ON
- Position 4 (Up) ON
- Position 5 (Down) OFF

8620C:

- BAND Band 4
- TIME-SECONDS1 — .01
- MODE AUTO
- TIME-SECONDS Vernier Fully clockwise

86290A:

- POWER LEVEL Fully counterclockwise
- ALC SLOPE OFF
- ALC INT
- RF ON-OFF ON

8755A:

- OFFSET-CAL OFFSET (ON)
- OFFSET dB -10
- dB/DIV 5
- DISPLAY A

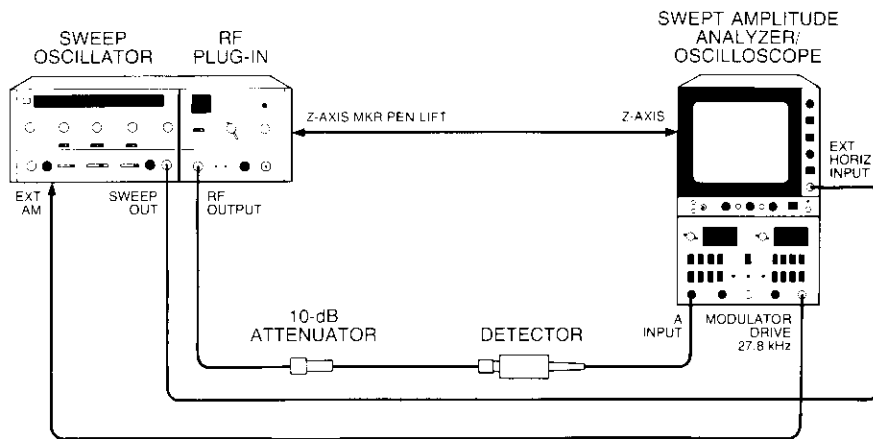

Figure 5-12. ALC Adjustments Setup Using 8755A Swept Amplitude Analyzer

 ADJUSTMENTS

5-26. ALC ADJUSTMENTS USING 8755A SWEEP AMPLITUDE ANALYZER (Cont'd)

- d. Connect equipment as shown in Figure 5-12.
- e. Press 8620C LINE pushbutton ON.
- f. Adjust SYMMETRY control A1R60 to set power level to -5 dBm at highest power point. There should be no holes or band discontinuities at switch points. (Disregard slope of display).
- g. Rotate POWER LEVEL control clockwise to set power level to $+5$ dBm at 18.0 GHz.
- h. Rotate SLOPE control clockwise until slope of trace is $+5$ dB from low end (2.0 GHz) to high end (18 GHz). (2.0 GHz = 0 dB and 18.0 GHz = $+5$ dB.)
- i. Rotate POWER LEVEL control counterclockwise until power is 0 dBm at high end (18 GHz). Low end (2.0 GHz) should be at -5 dBm. If not, adjust SYMMETRY control until slope is $+5$ dB from low end to high end.
- j. Rotate SLOPE and POWER LEVEL controls fully counterclockwise. Note power level. If necessary, adjust LO LEVEL CLAMP control A1R7 so that highest power point of trace is -5 dBm.
- k. Repeat steps c through f until low level power is at -5 dBm (maximum) and conditions in step e are obtained.

3. Internal Coupler/Detector Compensation

- a. Set 86290A controls as shown in step 2c. Set 8755A dB/DIV to .25. Press 8620C CW pushbutton; set CW MARKER pointer to 2.0 GHz.
- b. Rotate POWER LEVEL control clockwise to align trace dot with calibration line drawn in step 1. Press 8620C FULL SWEEP pushbutton. Display should be similar to either Waveform 1 or Waveform 2 of Figure 5-13.

NOTE

If display is similar to Waveform 1, use procedure in step c; use procedure in step d for displays similar to Waveform 2. Due to interaction of controls, some iteration may be necessary.

- c. Adjustments for Waveform 1 (Figure 5-13):
 - (1) Adjust F1 control A1R29 and G1 control A1R36 so the first three-quarters of the trace conforms to shape of calibration line drawn in step 1 (WAVEFORM 3).
 - (2) Adjust F2 control A1R42 and G2 control A1R55 to shape last portion of trace. (Typical adjusted response is shown as WAVEFORM 4).
 - d. Adjustment for Waveform 2 (Figure 5-13):
 - (1) Adjust F2 control A1R42 and G2 control A1R55 so the first three-quarters of the trace conforms to shape of calibration line drawn in step 1 (WAVEFORM 3).
 - (2) Adjust F1 control A1R29 and G1 control A1R36 to shape last portion of trace. (Typical adjusted response is shown as WAVEFORM 4.)
-

ADJUSTMENTS

5-26. ALC ADJUSTMENTS USING 8755A SWEPT AMPLITUDE ANALYZER (Cont'd)

Figure 5-13. Detector Compensation Adjustment Waveforms

- e. With compensation adjustment complete, peak-to-peak variation of display should be less than 1.8 dB ($< \pm .9$ dB).
 - f. Set 8755A dB/DIV to 5. Set display to centerline using OFFSET control.
 - g. Adjust 86290A POWER LEVEL control to set power level at +5 dBm on 8755A.
 - h. Set display to centerline on 8755A using OFFSET control. Set dB/DIV to .25.
 - i. Peak-to-peak variation of display should be less than 1.8 dB (± 0.9 dB).
 - j. Recheck step 2 to ensure that the LO LEVEL CLAMP and SYMMETRY adjustments have not changed.
4. *PIN UPPER CLAMP and GAIN SHAPING Adjustments*
- a. On RF Plug-in front panel, set SLOPE to OFF and POWER LEVEL fully counterclockwise.
 - b. Set 8755A dB/DIV to 5.

ADJUSTMENTS

5-26. ALC ADJUSTMENTS USING 8755A SWEEP AMPLITUDE ANALYZER (Cont'd)

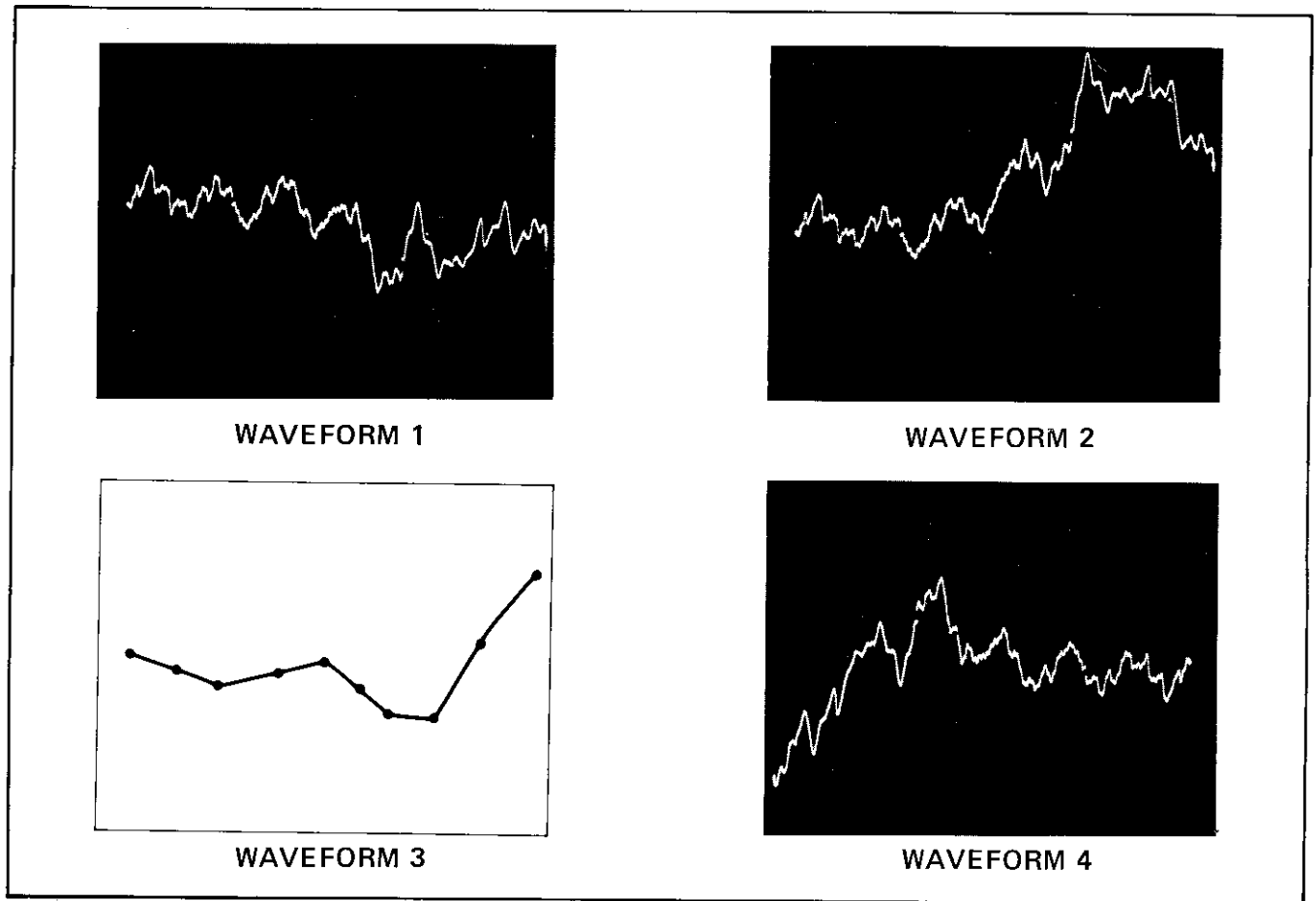
- c. Rotate PIN UPPER CLAMP potentiometer A1R75 clockwise until display starts to become unlevelled.
- d. Rotate PIN UPPER CLAMP potentiometer counterclockwise approximately 10°.
- e. Rotate GAIN SHAPING potentiometer A1R71 over full range to locate position that gives best flatness with no oscillations while rotating POWER LEVEL control over full range.

5. UPPER POWER CLAMP Adjustment

- a. Set position # 3 of ALC Function switch A1S1 Down (OFF).
- b. Select Band 1.
- c. Rotate POWER LEVEL control fully clockwise.
- d. Adjust front-panel PEAK control for maximum unlevelled power across band.
- e. Adjust UPPER POWER CLAMP (HI) potentiometer A1R10 so power is either leveled to +11 dBm or to same level as the minimum unlevelled power point of the band, whichever is less.

NOTE

Trace may be level with the UPPER POWER CLAMP fully counterclockwise.

- f. Reset position # 3 of ALC Function switch A1S1 Up (ON).

6. GAIN PRESET Adjustment

Figure 5-14. GAIN PRESET Adjustment Setup

ADJUSTMENTS

5-26. ALC ADJUSTMENTS USING 8755A SWEPT AMPLITUDE ANALYZER (Cont'd)

- a. Connect equipment as shown in Figure 5-14.
- b. Select EXT ALC on plug-in and rotate ALC GAIN control fully counterclockwise, then rotate clockwise 15°.
- c. Select 0.2 VOLTS/DIV sensitivity on oscilloscope. Set oscilloscope input switch to GND, set trace to top graticule line, then return input switch to DC.
- d. Rotate GAIN PRESET control A1R59 fully clockwise.
- e. Rotate POWER LEVEL control slowly over entire range and look for oscillations on oscilloscope display.
- f. If oscillations occur, adjust GAIN PRESET counterclockwise until oscillations just disappear.
- g. Rotate POWER LEVEL control slowly through full range. As POWER LEVEL control is rotated, oscillations may occur. (See Figure 3-9.)

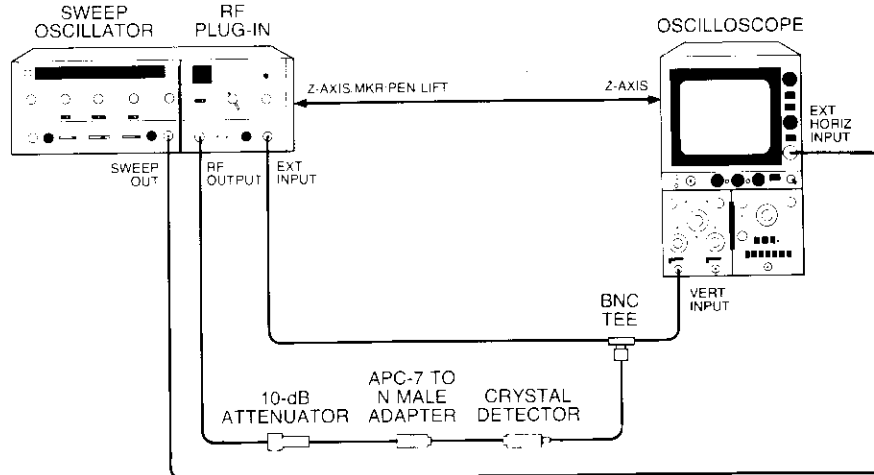
NOTE

Flatness may degrade at maximum and minimum power levels.

- h. If oscillations occur, continue to adjust GAIN PRESET counterclockwise to remove all oscillations over full range of POWER LEVEL control.
7. *Power Meter Leveling Check*

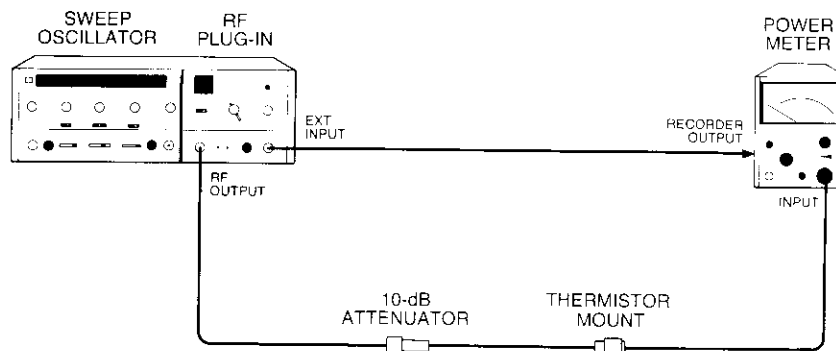

Figure 5-15. Power Meter Leveling Setup

- a. Connect equipment as shown in Figure 5-15.
- b. Select Band 4.
- c. Ensure that power meter indication is level with +0.15 dB, and without oscillations, over full range of POWER LEVEL control.
- d. If oscillations occur, adjust GAIN PRESET control A1R59 counterclockwise. (See step 6f).

ADJUSTMENTS

5-27. ALC ADJUSTMENTS (Alternate Procedure)

REFERENCE:

SERVICE SHEET 1, A1 ALC ASSEMBLY

DESCRIPTION:

Symmetry is adjusted so square wave modulation is symmetrical over full range of POWER LEVEL and SLOPE controls. PIN UPPER CLAMP is adjusted for optimum flatness of oscilloscope trace. LO LEVEL CLAMP sets minimum power level.

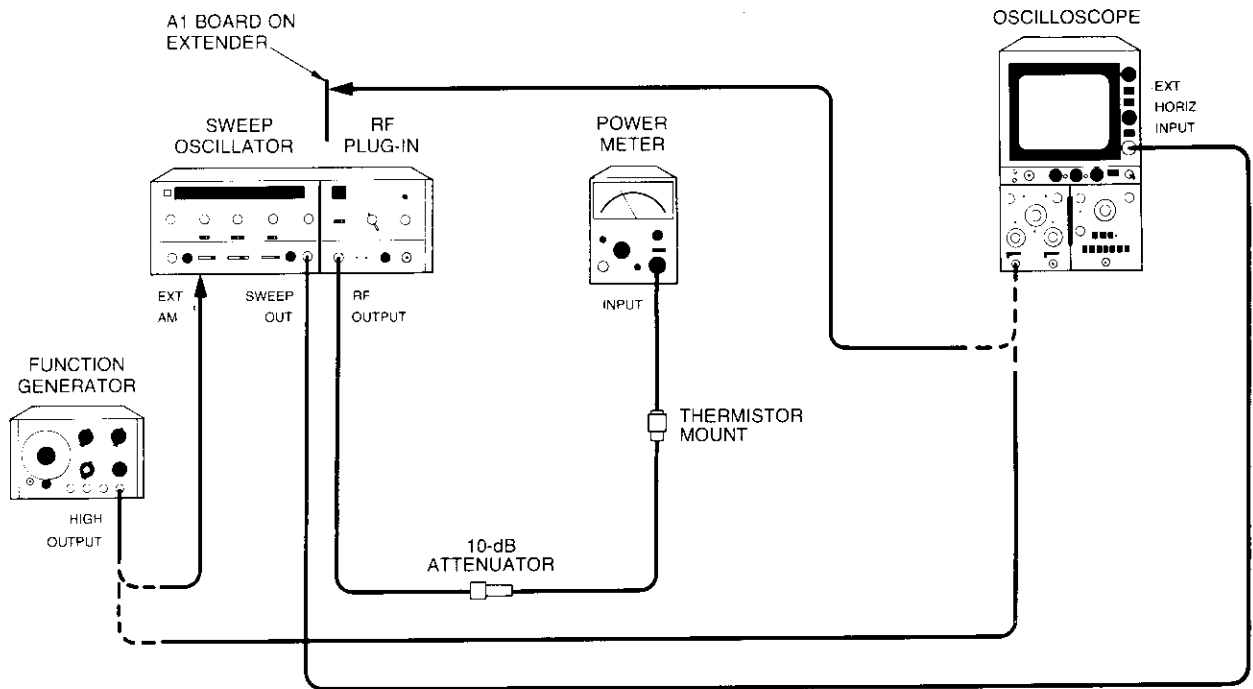

Figure 5-16. ALC Adjustments Test Setup

NOTE

Equipment listed is for two test setups, Figures 5-16 and 5-17.

EQUIPMENT:

Sweep Oscillator	HP 8620C
RF Plug-in	HP 86290A
Function Generator	HP 3310A
Oscilloscope	HP 182C/1801A/1820C
Power Meter	HP 432A
Thermistor Mount	HP 8478A
10-dB Attenuator	HP 8491B, Option 010
APC-7 to N Male Adapter	HP 11525A
Crystal Detector	HP 8470A

change p. 7-3

Reduce Par. 5-27 with par. 7-9, page 7-12 **ADJUSTMENTS**

5-27. ALC ADJUSTMENTS (Alternate Procedure) (Cont'd)

PROCEDURE:

- a. Connect equipment as shown in Figure 5-16 with oscilloscope connected to function generator. Set function generator to 27.8 kHz square wave, and amplitude (as shown on oscilloscope) to $\pm 6V$ p-p.
- b. Set oscilloscope to 10 microseconds/division internal sweep time and 0.05V/division vertical sensitivity.
- c. Set controls as follows:

8620C:

BAND Band 4
 MODE AUTO
 TIME-SECONDS1 — .01
 TIME-SECONDS Vernier Fully clockwise

86290A:

RF OFF-ON ON
 ALC INT
 POWER LEVEL Fully counterclockwise
 ALC SLOPE OFF

86290A A1 ALC Board (Component Locations Figure 5-24):

PIN (PIN UPPER CLAMP) Fully counterclockwise
 SYMM (SYMMETRY) Midrange
 HI (UPPER POWER CLAMP) Fully counterclockwise
 LO (LO LEVEL CLAMP) Fully counterclockwise

- d. Press 8620C LINE pushbutton ON.
- e. Note power meter reading. Turn function generator OFF and observe power meter reading. Adjust A1 SYMM control A1R60 for exactly 3-dB change between function generator ON and OFF.
- f. Press 8620C CW pushbutton. Adjust CW MARKER control for maximum power meter indication.
- g. Adjust A1 LO control A1R7 for maximum power point of -5 dBm. Press 8620C FULL SWEEP pushbutton.
- h. Repeat steps e through g until interaction is negligible.
- i. Adjust 86290A POWER LEVEL and PEAK controls for maximum leveled power. Set POWER LEVEL control for 0 dBm power output indication on power meter.
- j. Connect equipment as shown in Figure 5-17 with power meter connected to 86290A RF OUTPUT. Draw a calibration line on oscilloscope using procedure in Paragraph 5-26, step 1. Change all references to 8755A to oscilloscope and delete all references to MODULATOR DRIVE. Oscilloscope should be on most sensitive range.
- k. Press 8620C FULL SWEEP pushbutton.

ADJUSTMENTS

5-27. ALC ADJUSTMENTS (ALTERNATE PROCEDURE) (Cont'd)

- i. Display should be similar to either Waveform 1 or Waveform 2 in Figure 5-13.

NOTE

If display is similar to Waveform 1, use procedure in step m; use procedure in step n for displays similar to Waveform 2. Due to interaction of controls, some iteration may be necessary.

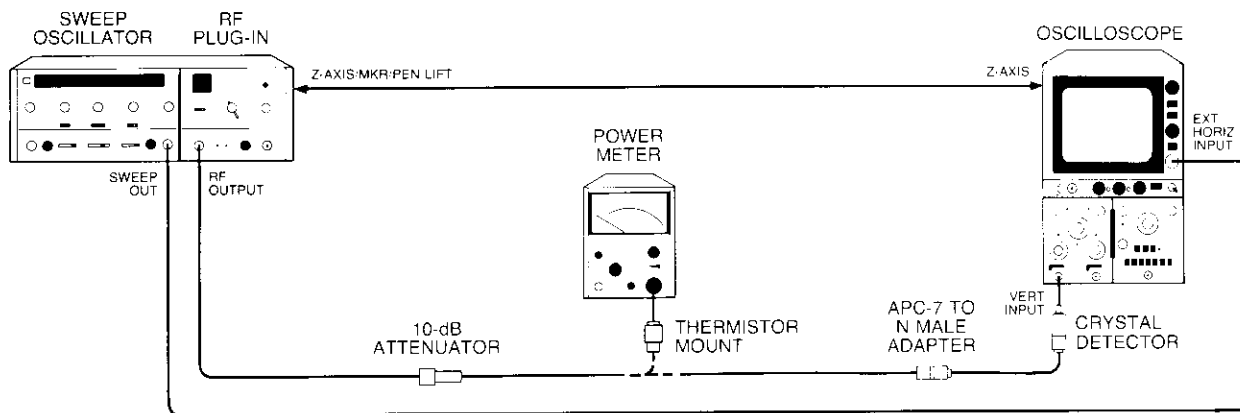

Figure 5-17. Detector compensation Adjustment Test Setup

- m. Adjustment for Waveform 1 (Figure 5-13):
 - (1) Adjust F1 control A1R29 and G1 control A1R36 so the first three-quarters of the trace conforms to shape of calibration line drawn in step j.
 - (2) Adjust F2 control A1R42 and G2 control A1R55 to shape last portion of trace.
- n. Adjustment for Waveform 2 (Figure 5-13):
 - (1) Adjust F2 control A1R42 and G2 control A1R55 so the first three-quarters of the trace conforms to shape of calibration line drawn in step j.
 - (2) Adjust F1 control A1R29 and G1 control A1R36 to shape last portion of trace.
- o. Adjust 86290A POWER LEVEL and PEAK controls for maximum leveled power. Press 8620C CW pushbutton.

ADJUSTMENTS

5-27. ALC ADJUSTMENTS (Alternate Procedure) (Cont'd)

- p. Rotate CW MARKER control over full band and note lowest power point. Adjust CW MARKER control to lowest power point. Note oscilloscope trace dot position.
- q. Connect power meter to 86290A RF OUTPUT. Rotate POWER LEVEL control counterclockwise to decrease output power indication on power meter by 1.8 dB.
- r. Connect oscilloscope to 86290A RF OUTPUT. Note position of oscilloscope trace dot. The area between the two trace dot positions noted represents the leveling tolerance of ± 0.9 dB.
- s. With Detector Compensation adjustments complete, peak-to-peak variation of display should be within leveling tolerance noted in step r.
- t. Connect oscilloscope to 86290A A1TP6 as shown in Figure 5-16.
- u. Select Band 1 on 8620C. Set 86290A POWER LEVEL control fully clockwise. Set ALC Function switch A1S1 Position # 3 Down (OFF).
- v. Adjust A1 HI control A1R10 for maximum leveled power across the band.
- w. Set ALC Function switch A1S1 Position # 3 Up (ON). Set 86290A POWER LEVEL control fully counterclockwise.
- x. Adjust A1 PIN control A1R75 clockwise until degradation in low level flatness occurs. Adjust A1 PIN control counterclockwise until optimum low level flatness is just achieved. Set A1 PIN control an additional 10° counterclockwise to ensure sufficient modulator bias current range. Rotate GAIN SHAPING control A1R71 over full range to locate position which gives best flatness with no oscillations.
- z. Go to paragraph 5-26 and perform adjustments in Steps 6 and 7.

5-28. BAND SWITCH OVERLAP ADJUSTMENTS

REFERENCE

Service Sheet 5, SWEEP CONTROL ASSEMBLY and Service Sheet 6, STOP SWEEP ASSEMBLY.

DESCRIPTION:

Adjust appropriate ends of Bands 1 through 3 for frequency accuracy to ensure smooth switchpoint transitions in Sequential Band 4.

ADJUSTMENTS

5-28. BAND SWITCH OVERLAP ADJUSTMENTS (Cont'd)

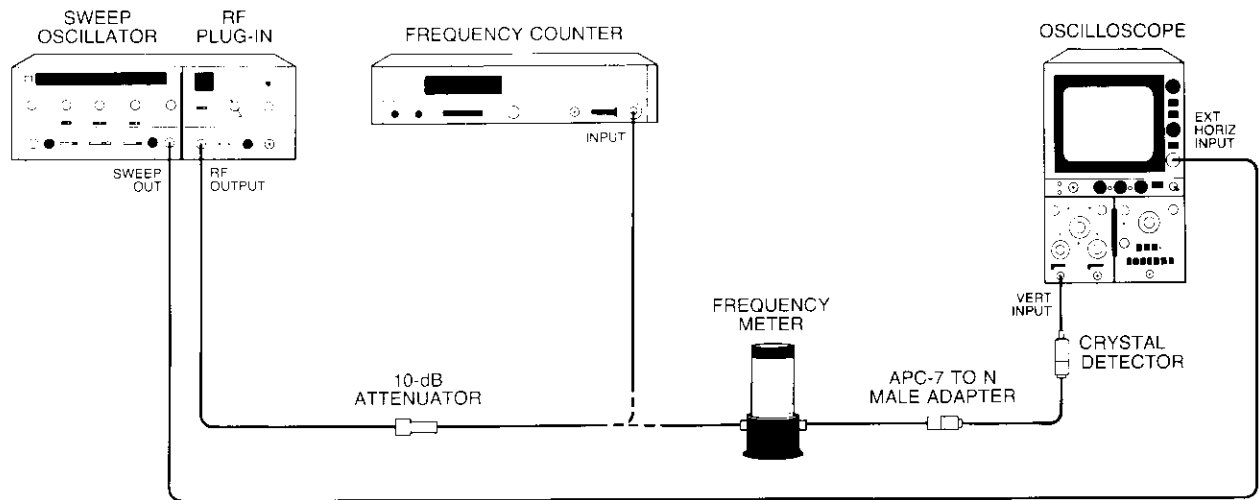

Figure 5-18. Band Switch Overlap Adjustment Test Setup

EQUIPMENT:

Sweep Oscillator	HP 8620C
RF Plug-in	HP 86290A
10-dB Attenuator	HP 8491B, Option 010
APC-7 to N Male Adapter	HP 11525A
Crystal Detector	HP 8470A
Oscilloscope	HP 182C/1801A/1820C
Frequency Meter	HP 537A

PROCEDURE:

- a. Set controls as follows:

8620C:

BAND	Band 4
TIME-SECONDS1 — .01
TIME-SECONDS Vernier	Fully clockwise

86290A:

POWER LEVEL	Fully clockwise
-------------------	-----------------

- b. Connect equipment as shown in Figure 5-18 with frequency counter connected to 86290A RF OUTPUT. Press 8620C LINE switch ON. Press CW and CW VERNIER pushbuttons. Adjust CW MARKER and CW VERNIER controls for frequency counter indication of 6.200 GHz.
- c. Connect oscilloscope and frequency meter to 86290A RF OUTPUT. Set oscilloscope for external horizontal sweep; MAGNIFIER to X10. Center trace dot on oscilloscope.

ADJUSTMENTS

5-28. BAND SWITCH OVERLAP ADJUSTMENTS (Cont'd)

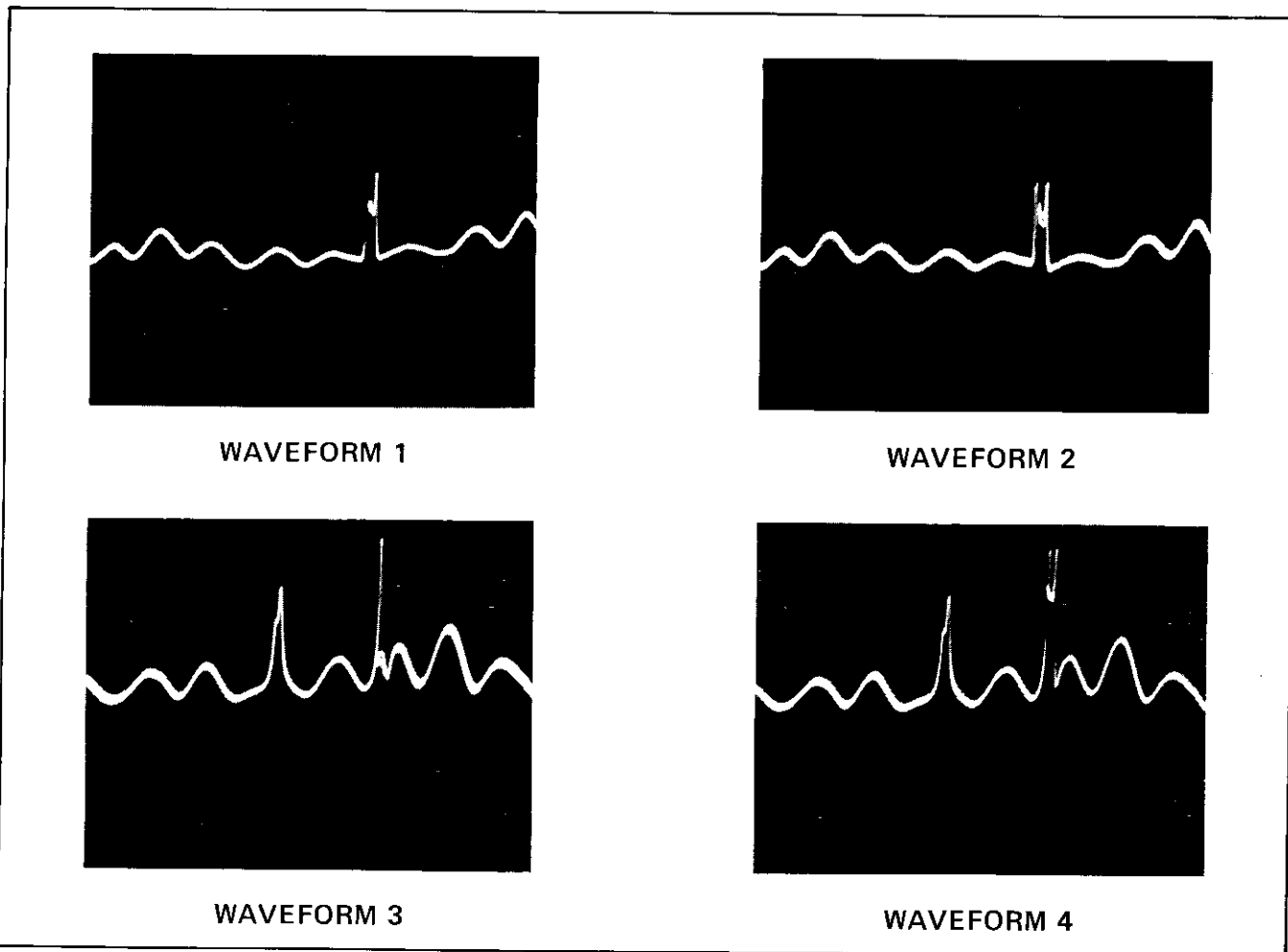

Figure 5-19. Band Switch Overlap Adjustment Waveforms

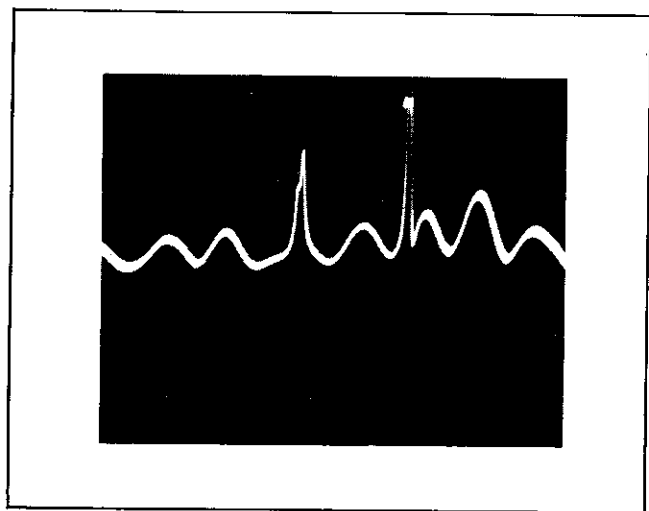

Figure 5-20. Typical Small Overlap Display

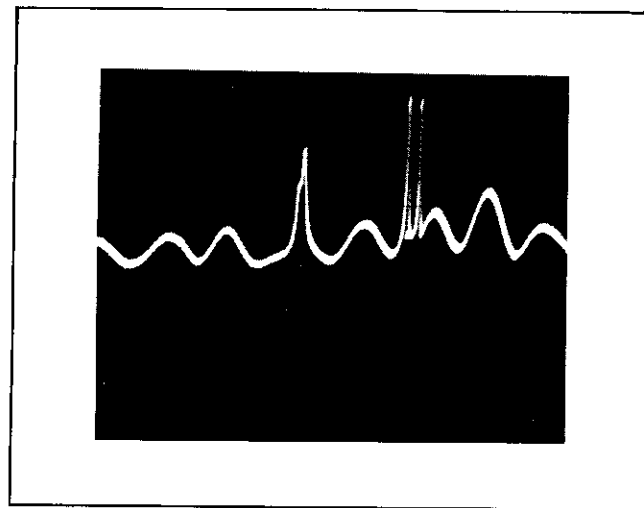

Figure 5-21. Typical Large Overlap Display

ADJUSTMENTS

5-28. BAND SWITCH OVERLAP ADJUSTMENTS (Cont'd)

- d. Adjust frequency meter around 6.2 GHz to peak trace dot. Press 8620C FULL SWEEP pushbutton.
- e. Adjust A6 LO control A6R2 so that display appears as shown in Figure 5-19, Waveform 1.
- f. Adjust A5 BAND 1 HI control A5R22 so that display appears as shown in Figure 5-19, Waveform 2.
- g. Connect frequency counter to 86290A RF OUTPUT. Press 8620C CW and CW VERNIER pushbuttons.
- h. Adjust CW MARKER control for frequency counter indication slightly less than 6.200 GHz. Slowly rotate CW VERNIER control to increase frequency while monitoring frequency counter. Note highest frequency before switchpoint occurs and also frequency just after switchpoint occurs.
- i. Frequency indication just before switchpoint occurs should be higher than frequency just after switchpoint by $25 \text{ MHz} \pm 20 \text{ MHz}$. This indicates an overlap of Band 1 and Band 2.
- j. If condition of step i is not met, reconnect oscilloscope and repeat steps e and f adjusting for more or less overlap as required (Figure 5-20 and 5-21).
- k. With frequency counter connected to 86290A RF OUTPUT, adjust CW MARKER and CW VERNIER controls for a frequency counter indication of 12.400 GHz.
- l. Connect oscilloscope to 86290A RF OUTPUT. Center trace dot on oscilloscope.
- m. Adjust frequency meter around 12.4 GHz to peak trace dot. Press 8620C FULL SWEEP pushbutton.
- n. Adjust A6 HI control A6R6 so that display appears as shown in Figure 5-19, Waveform 3.
- o. Adjust A5 BAND 3 B control so that display appears as shown in Figure 5-19, Waveform 4. Some iteration may be necessary due to interaction of controls.
- p. Connect frequency counter to 86290A RF OUTPUT. Press CW and CW VERNIER pushbuttons.
- q. Adjust CW MARKER control for frequency counter indication slightly less than 12.400 GHz. Slowly rotate CW VERNIER control to increase frequency while monitoring frequency counter. Note highest frequency just before switchpoint occurs and also frequency just after switchpoint occurs.
- r. Frequency just before switchpoint should be higher than frequency just after switchpoint by $25 \text{ MHz} \pm 20 \text{ MHz}$. This indicates an overlap of Band 2 and Band 3.
- s. If condition of step r is not met, reconnect oscilloscope and repeat steps n and o adjusting for more or less overlap as required (Figures 5-20 and 5-21).

ADJUSTMENTS

5-29. FREQUENCY REFERENCE CALIBRATION ADJUSTMENT

REFERENCE:

SERVICE SHEET 3, YIG TUNED OSCILLATOR DRIVER ASSEMBLY.

DESCRIPTION:

Calibrates Frequency Reference output to approximately +1 volt/GHz.

EQUIPMENT:

Use test setup in Figure 5-2.

PROCEDURE:

- a. Select Band 4 and press CW pushbutton.
- b. Adjust CW MARKER control for frequency counter indication of 4.000 GHz \pm 0.001 GHz.
- c. Connect digital voltmeter to 86290A FREQ REF BNC connector J5 (rear panel).
- d. Adjust A3 C control A3R63 for digital voltmeter indication of 4.000 Vdc \pm 0.001 Vdc.
- e. Adjust CW MARKER control for frequency indication of 12.000 GHz \pm 0.001 GHz.
- f. Adjust A3 B control A3R55 for 12.000 Vdc \pm 0.001 Vdc.
- g. Repeat steps b through f until no interaction is apparent.

change page 7-3

Replace par. 5-3f with par. 7-10, page 7-15

5-30. FREQUENCY MODULATION SENSITIVITY ADJUSTMENT

REFERENCE:

SERVICE SHEET 4, FREQUENCY MODULATION ASSEMBLY

DESCRIPTION:

Sets output of FM DRIVER circuit for proper match to YIG-TUNED OSCILLATOR sensitivity. Must be performed whenever either A4 FM ASSEMBLY or A9 YIG-TUNED OSCILLATOR is replaced.

EQUIPMENT:

Test equipment not required.

ADJUSTMENTS

5-30. FREQUENCY MODULATION SENSITIVITY ADJUSTMENT (Cont'd)**PROCEDURE:**

- a. Note FM coil sensitivity stamped on label on YIG-TUNED OSCILLATOR.
- b. Refer to Table 5-4 to determine value of A4R46* using FM coil sensitivity noted in step a.
- c. Install resistor selected in step b. Refer to Figure 8-27 for component location.
- d. To verify proper FM operation, refer to paragraph 4-14, EXTERNAL FREQUENCY MODULATION TEST.